

INTERNAL CENTRAL DIVISION

40mm Encapsulated
RHS Bracings

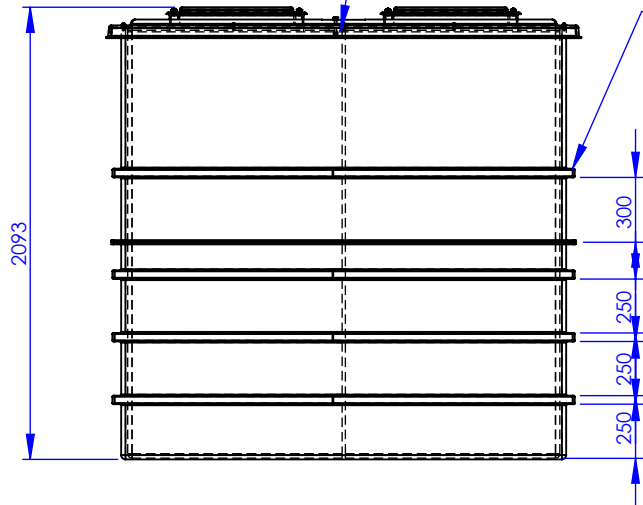

TWO PIECE
SPLIT TANK

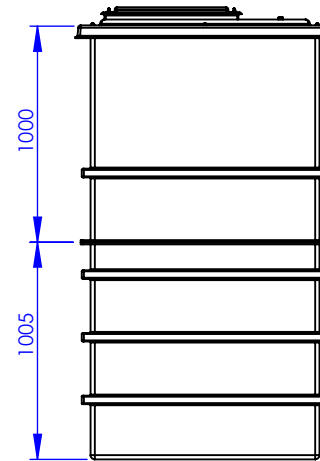

TITLE
PW4001-2.DIV.AG - TD

DRAWN BY
D.PRYJMACHUK

DATE
28/10/2024

NOTE:
All tanks must be fully supported on a flat, level & continuous foundation providing structural support to the tank when full to maximum operating capacity. It is essential that the user refers to the conditions of installation document prior to the installation of the tank. Under no circumstances should the tank body be used to provide support to pipework and ancillary items. The tank lid is a structural part of the tank and must be in place and fitted correctly when water is contained within the tank.

DESCRIPTION:
PW4001-2.DIV.AG - TD
PW4001-2.DIV.AG - TD Two piece divided cold water storage tank suitable for an AG/AF Airgap

TANK SPECIFICATION :

| | |
|----------------------|----------------------|
| INTERNAL DIMENSIONS | 2000 x 1000 x 2000mm |
| EXTERNAL DIMENSIONS | 2200 x 1200 x 2093mm |
| NOM. CAPACITY | 4000 Litres |
| DRY WEIGHT | xxx KG |
| INSULATION THICKNESS | 25mm |
| MATERIAL | GRP |

