

Internal Central Divider

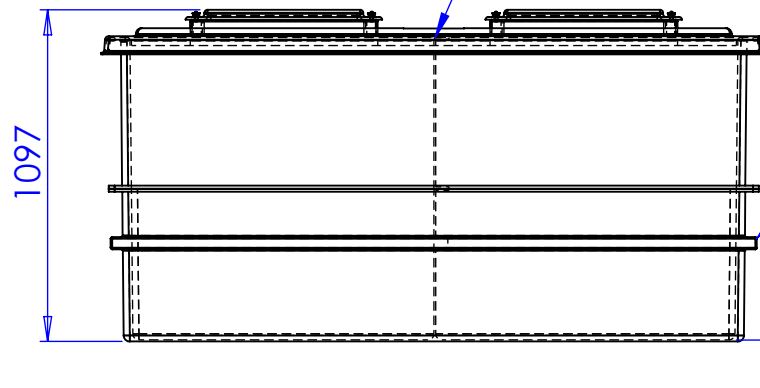

40mm STEEL BRACES

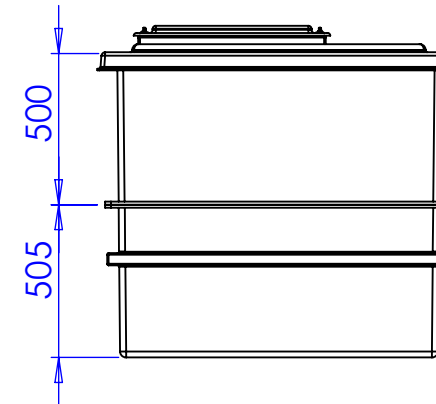

TWO PIECE SPLIT TANK

TITLE
PW2000-2.DIV.AG - TD

DRAWN BY
D.PRYJMACHUK

DATE
17/10/2024

NOTE:
All tanks must be fully supported on a flat, level & continuous foundation providing structural support to the tank when full to maximum operating capacity. It is essential that the user refers to the conditions of installation document prior to the installation of the tank. Under no circumstances should the tank body be used to provide support to pipework and ancillary items. The tank lid is a structural part of the tank and must be in place and fitted correctly when water is contained within the tank.

DESCRIPTION:
PW2000-2.DIV.AG - TD
PW2000 Two piece divided cold water storage tank suitable for an AG/AF Air gap

| TANK SPECIFICATION : | |
|----------------------|----------------------|
| INTERNAL DIMENSIONS | 2000 x 1000 x 1000mm |
| EXTERNAL DIMENSIONS | 2200 x 1200 x 1097mm |
| NOM. CAPACITY | 2000 Litres |
| DRY WEIGHT | xxx KG |
| INSULATION THICKNESS | 25mm |
| MATERIAL | GRP |

