

Internal Central Division

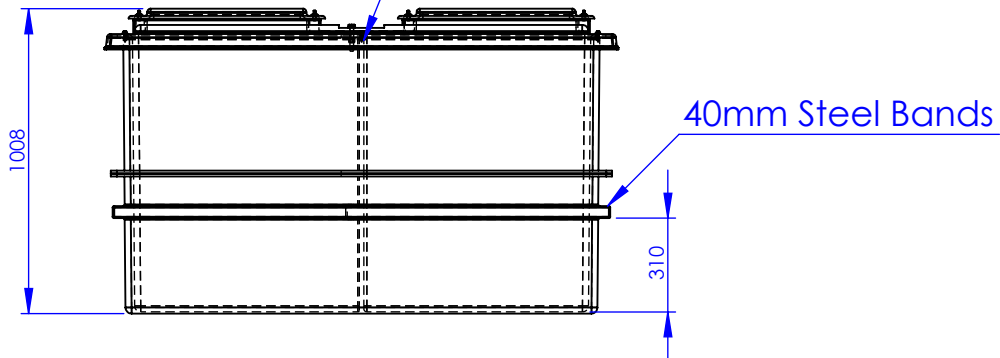

TWO PIECE SPLIT TANK

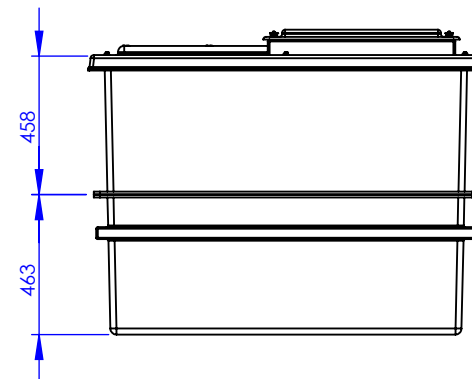

TITLE  
PW1590-2.DIV.AG - TD

DRAWN BY  
D.PRYJMACHUK

DATE  
17/10/2024

**NOTE:**  
All tanks must be fully supported on a flat, level & continuous foundation providing structural support to the tank when full to maximum operating capacity. It is essential that the user refers to the conditions of installation document prior to the installation of the tank. Under no circumstances should the tank body be used to provide support to pipework and ancillary items. The tank lid is a structural part of the tank and must be in place and fitted correctly when water is contained within the tank.

DESCRIPTION:  
PW1590-2.DIV.AG - TD  
PW1590 Two piece divided cold water storage tank suitable for an AG/AF Air gap

**TANK SPECIFICATION :**

|                      |                      |
|----------------------|----------------------|
| INTERNAL DIMENSIONS  | 1524 x 1143 x 915mm  |
| EXTERNAL DIMENSIONS  | 1700 x 1310 x 1008mm |
| NOM. CAPACITY        | 1590 Litres          |
| DRY WEIGHT           | xxx KG               |
| INSULATION THICKNESS | 25mm                 |
| MATERIAL             | GRP                  |

