

Internal Central Division

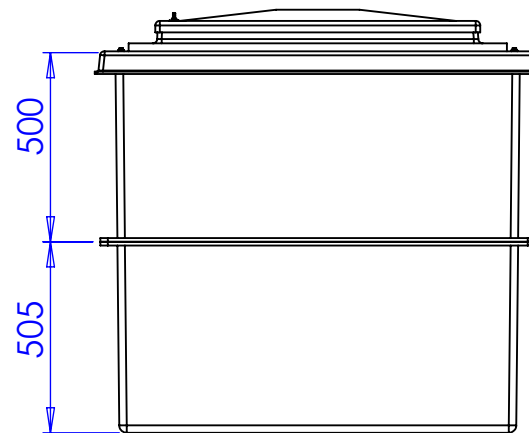
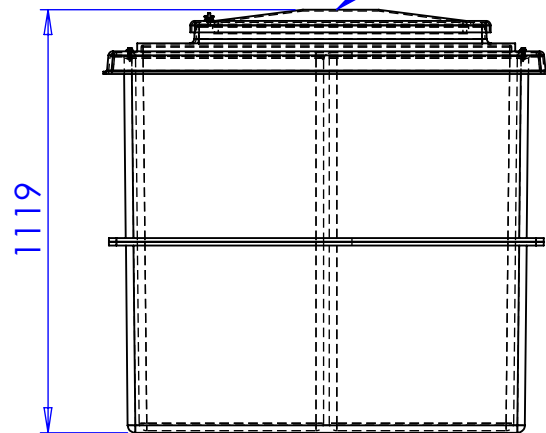

TWO PIECE SPLIT TANK

TITLE
PW1000-2.DIV.AG - TD

DRAWN BY
D.PRYJMACHUK

DATE
17/10/2024

NOTE:
All tanks must be fully supported on a flat level & continuous foundation providing structural support to the tank when full to maximum operating capacity. It is essential that the user refers to the conditions of installation document prior to the installation of the tank. Under no circumstances should the tank body be used to provide support to pipework and ancillary items. The tank lid is a structural part of the tank and must be in place and fitted correctly when water is contained within the tank.

DESCRIPTION:
PW1000-2.DIV.AG - TD
PW1000 Two piece cold water storage tank AG Air Gap

SCALE:1:20 SHEET 1 OF 1

TANK SPECIFICATION :

INTERNAL DIMENSIONS	1000mm x 1000mm x 1000mm
EXTERNAL DIMENSIONS	1180mm x 1180mm x 1119mm
NOM. CAPACITY	1000 Litres
DRY WEIGHT	xxx KG
INSULATION THICKNESS	25mm
MATERIAL	GRP

