

Internal Central Division

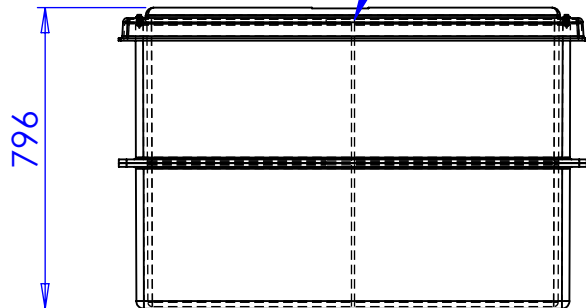

TWO PIECE SPLIT TANK

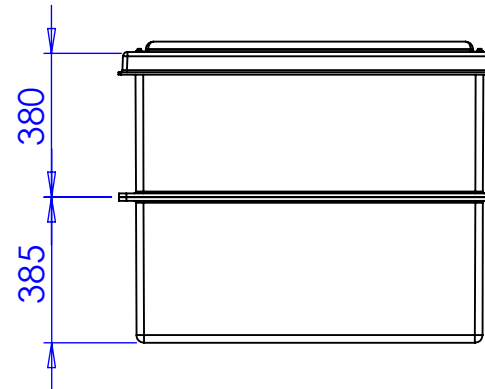

TITLE  
PW712-2.DIV.AG - TD

DRAWN BY  
D.PRYJMACHUK

DATE  
16/10/2024

**NOTE:**  
All tanks must be fully supported on a flat level & continuous foundation providing structural support to the tank when full to maximum operating capacity. It is essential that the user refers to the conditions of installation document prior to the installation of the tank. Under no circumstances should the tank body be used to provide support to pipework and ancillary items. The tank lid is a structural part of the tank and must be in place and fitted correctly when water is contained within the tank.

DESCRIPTION:  
PW712-2.DIV.AG - TD  
PW712.DIV Two piece divided cold water storage tank AG Air Gap

SCALE:1:20 SHEET 1 OF 1

**TANK SPECIFICATION :**

INTERNAL DIMENSIONS	1090mm x 860mm x 760mm
EXTERNAL DIMENSIONS	1240mm x 1010mm x 796mm
NOM. CAPACITY	712 Litres
DRY WEIGHT	xxx KG
INSULATION THICKNESS	25mm
MATERIAL	GRP

