

ITEM NO.	PART NUMBER	DESCRIPTION	QTY.
1	104032	Ø600 Mini Pump Chamber Carcass	1
2	017624	Cable Gland Locknut (Cream)	1
3	017623	Extended Thread Cable Gland (Cream)	1
4	404531	CWP1 Pump Internals - Leo Pump	1
5	1013862	Pump Auto Leo 1Ph 50Hz LSWm100CA	1
6	017744	Lockable Manhole Cover & Frame	1
7	011455	2 BA x 1.5 Inch Brass Slotted Hd Csk Screw	4
8	012620	2BA Brass Full Nut	4
9	011625	2 BA Brass Plain Washer	4

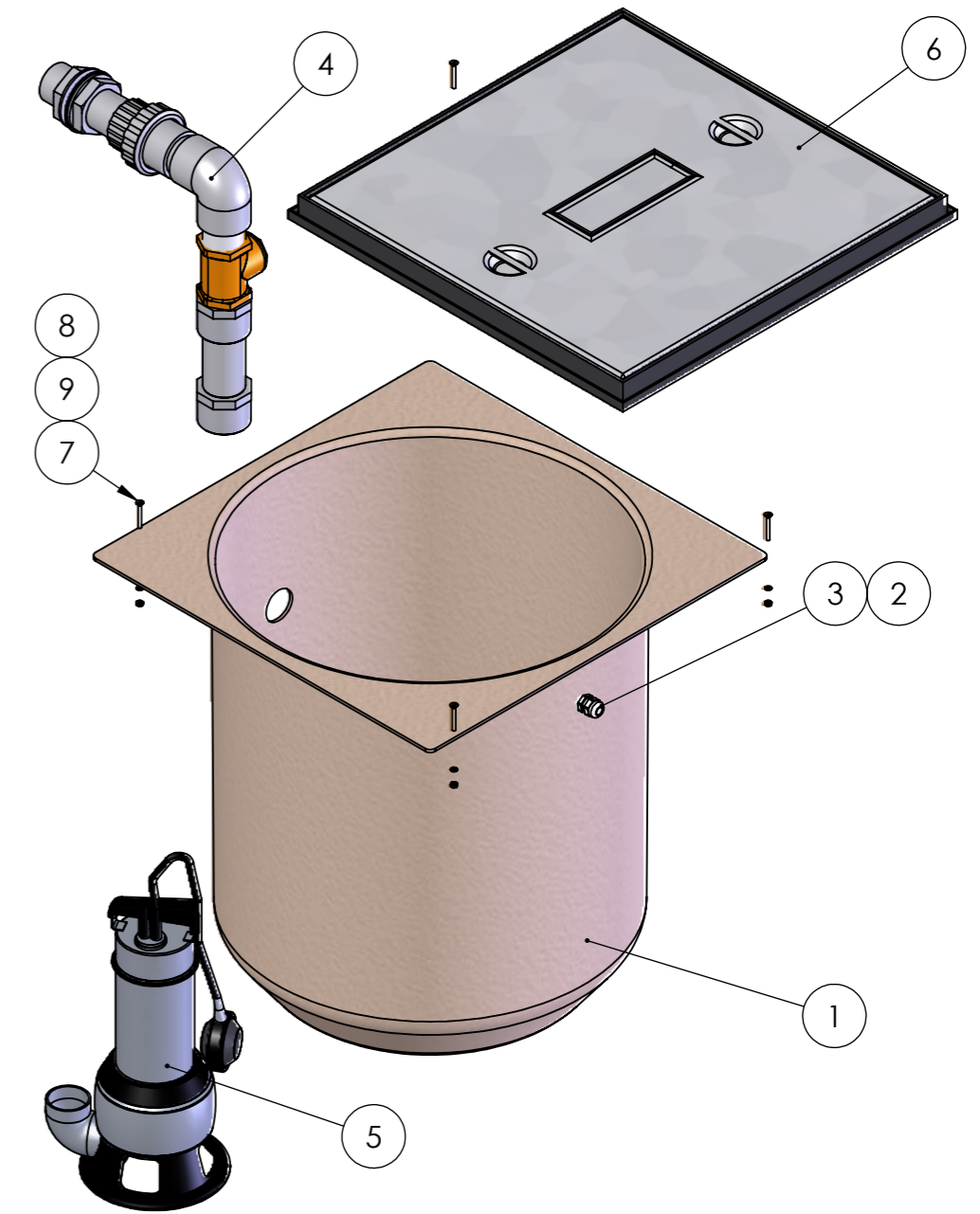

Please check with Kingspan Water & Energy for the latest Issue of the drawing				
Issue	Date	Drawn By	Approved By	Description
01	20/02/2025	TGY	TGY	Initial Issue - ECN 2179

Material : Various
 Finish :
 Weight : 42.60 Kg Kgs

Tolerance :
 Thickness : n/a
 Surface Area :

Drawing : CWP1S1P-B Page 1 of 1
 Ø0.6m CWP1 Pump Assembly No Inlet

All dimensions in mm
 Scale: Not to scale

Clearwater reserve the right to alter the details of this drawing without prior notice. This drawing is copyright and may not be reproduced or used without the written permission of Clearwater.

