

**Notes:**

- Pumpwell delivered without pumps installed. Pumps, Control panel & Float switches attached to pallet.
- Pumps to be coupled to chains with shackles on lifting chain which is connected to the unistrut assembly.
- Read Operating and Installation guidelines before installing.

Case Ø	Outlet Invert 'C'	Case Depth 'B'			Inlet Invert 'A'			Inlet Size 'E'
		PX5 17 (1.7m)	PX6 20 (2.0m)	PX7 26 (2.6m)	07 0.7m	10 1.0m	16 1.6m	
12 (1.2m)	0.65m	•			•			110mm
			•			•		160mm

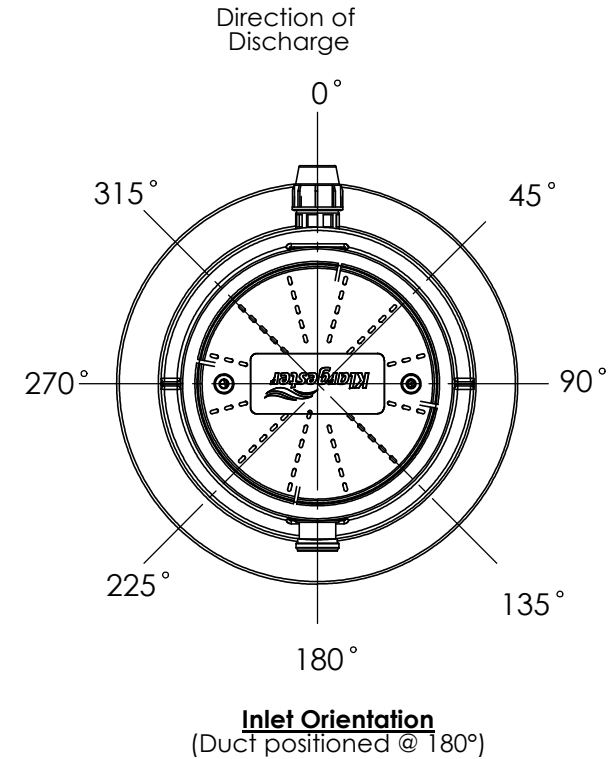
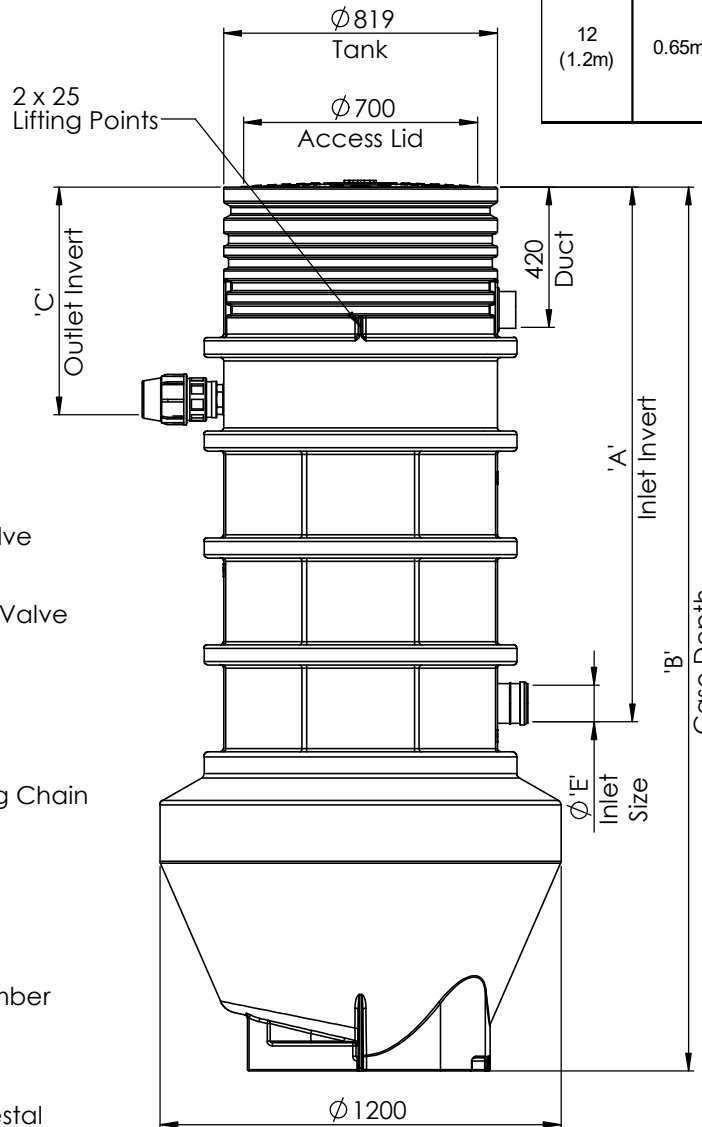
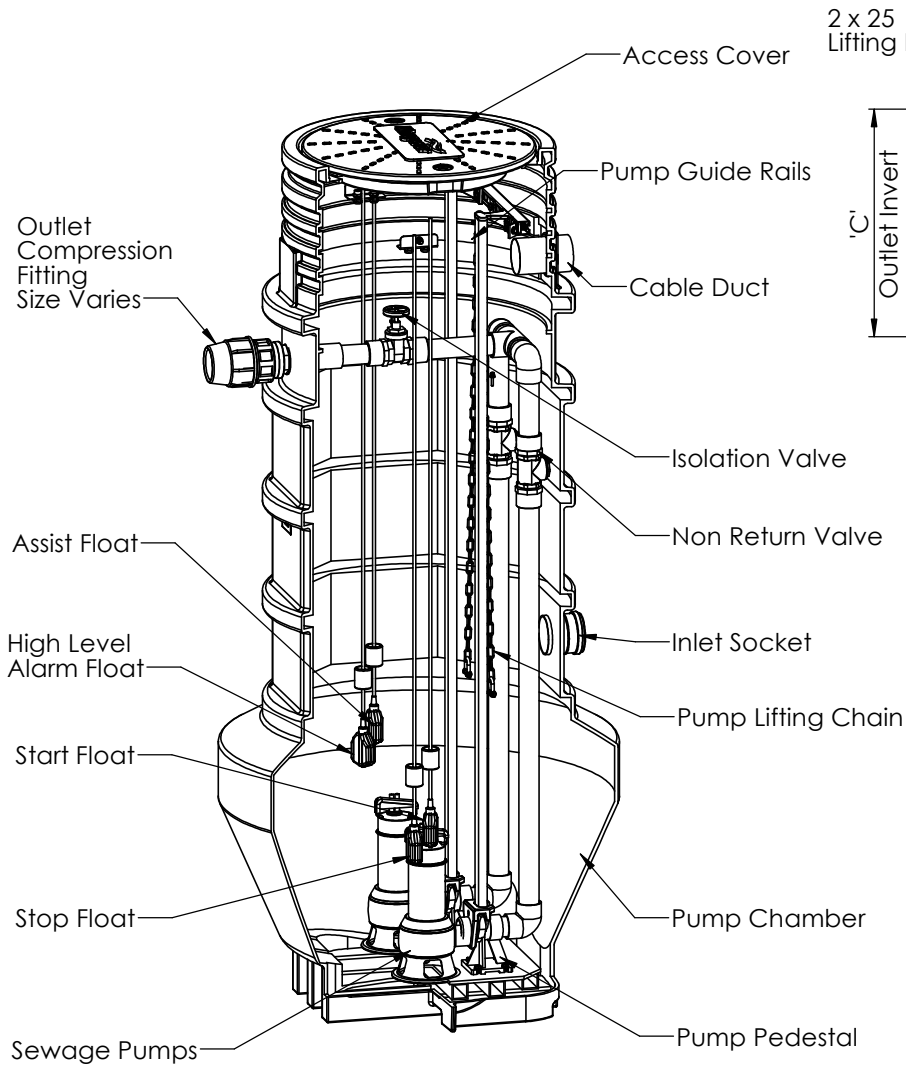

Please check with Kingspan Water & Energy for the latest Issue of the drawing

Issue	Date	Drawn By	Approved By	Description
02	14/11/2024	D.Musvaburi	D.M	ECN 2147
01	09/10/2024	D.Musvaburi	D.M	ECN 2128

LN Number :  
Finish :  
Weight :  
Modelled By :

Tolerance (unless stated) :  
Thickness :  
Surface Area : m<sup>2</sup>  
Material :

**Drawing : DS1486P**

Page 1 of 1

Ø1.2m PE Twin Sewage Pump Chamber

All Dimensions In mm Scale: Do Not Scale

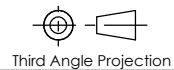

A:\Wastewater\Engineering\Drawing Data\02 - Sales Drawings\DS\DS - 14\DS1486P

Kingspan Water & Energy reserve the right to alter the details of this drawing without prior notice. This drawing is copyright and may not be reproduced or used without the written permission of Kingspan Water & Energy

