

Notes:

- Pumpwell delivered with pumps installed. Control panel and Float switch attached to pallet.
- Pumps to be coupled to chains with shackles supplied on lifting chain which is connected to the unistrut assembly.
- Read Operating and Installation guidelines before installing.

| Case Ø | Outlet Invert 'C' | Case Depth 'B' | | | Inlet Invert 'A' | | | Inlet Size 'E' |
|--------------|-------------------|----------------|--------------|--------------|------------------|------|------|----------------|
| | | PX2 | PX3 | PX4 | 05 | 11 | 14 | |
| | | 10 (1.0m) | 16 (1.6m) | 19 (1.9m) | 0.5m | 1.1m | 1.4m | |
| 09 (0.9m) | 0.5m | • | | | • | | | 110mm |
| | | | • | | | • | | 160mm |

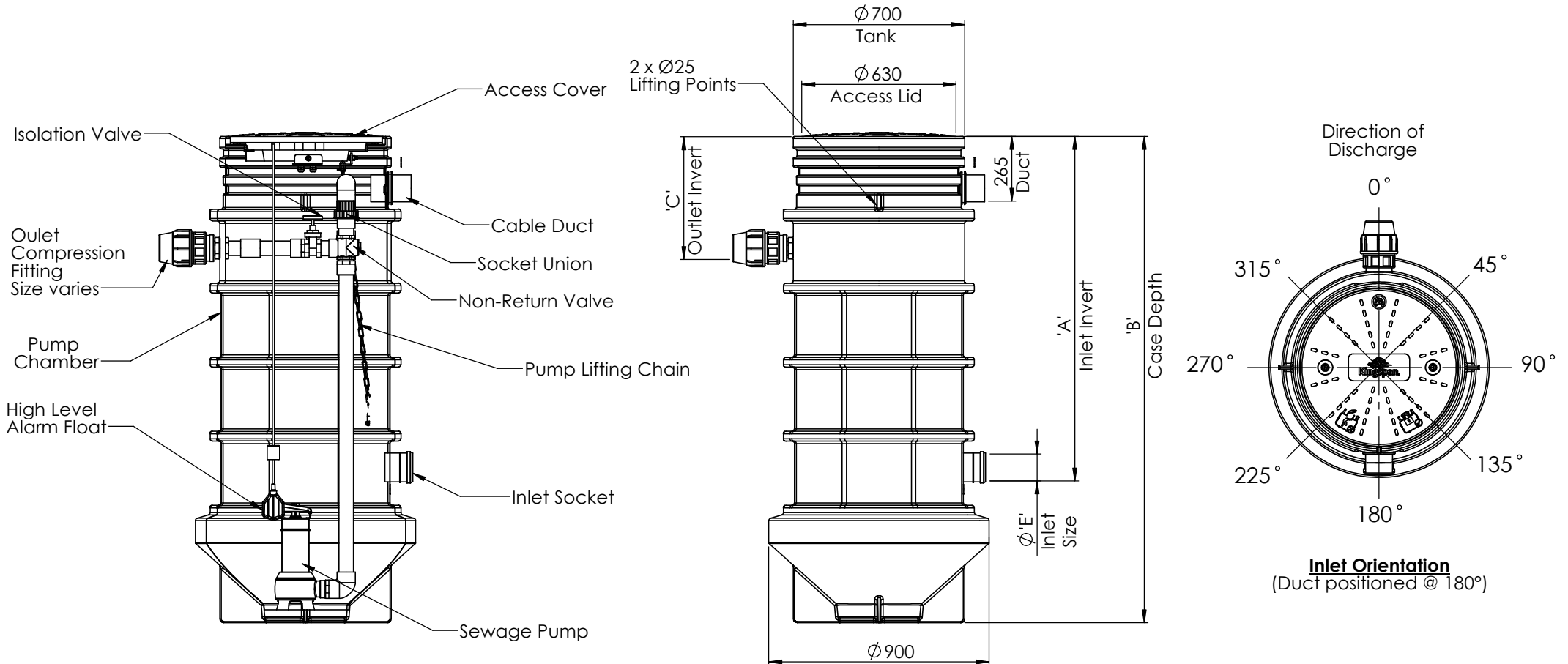

| Please check with Kingspan Water & Energy for the latest Issue of the drawing | | | | |
|---|------------|-------------|-------------|-------------|
| Issue | Date | Drawn By | Approved By | Description |
| 03 | 14/11/2024 | D.Musvaburi | D.M | ECN 2147 |
| 02 | 09/10/2024 | D.Musvaburi | D.M | ECN 2128 |

| | |
|---------------|-------------------------------|
| LN Number : | Tolerance (unless stated) : |
| Finish : | Thickness : |
| Weight : | Surface Area : m ² |
| Modelled By : | Material : |

Drawing : DS1489P Page 1 of 1
Ø0.9m PE Single Sewage Pump Chamber

All Dimensions In mm Scale: Do Not Scale

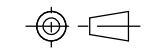
 Third Angle Projection

A:\Wastewater\Engineering\Drawing Data\02 - Sales Drawings\DS\DS - 14\DS1489P

Kingspan Water & Energy reserve the right to alter the details of this drawing without prior notice. This drawing is copyright and may not be reproduced or used without the written permission of Kingspan Water & Energy

