

Water Management Solutions

Klargester Hillmaster Pump Range Product Guide

Complete Wastewater and
Surface Water Pumping Solutions

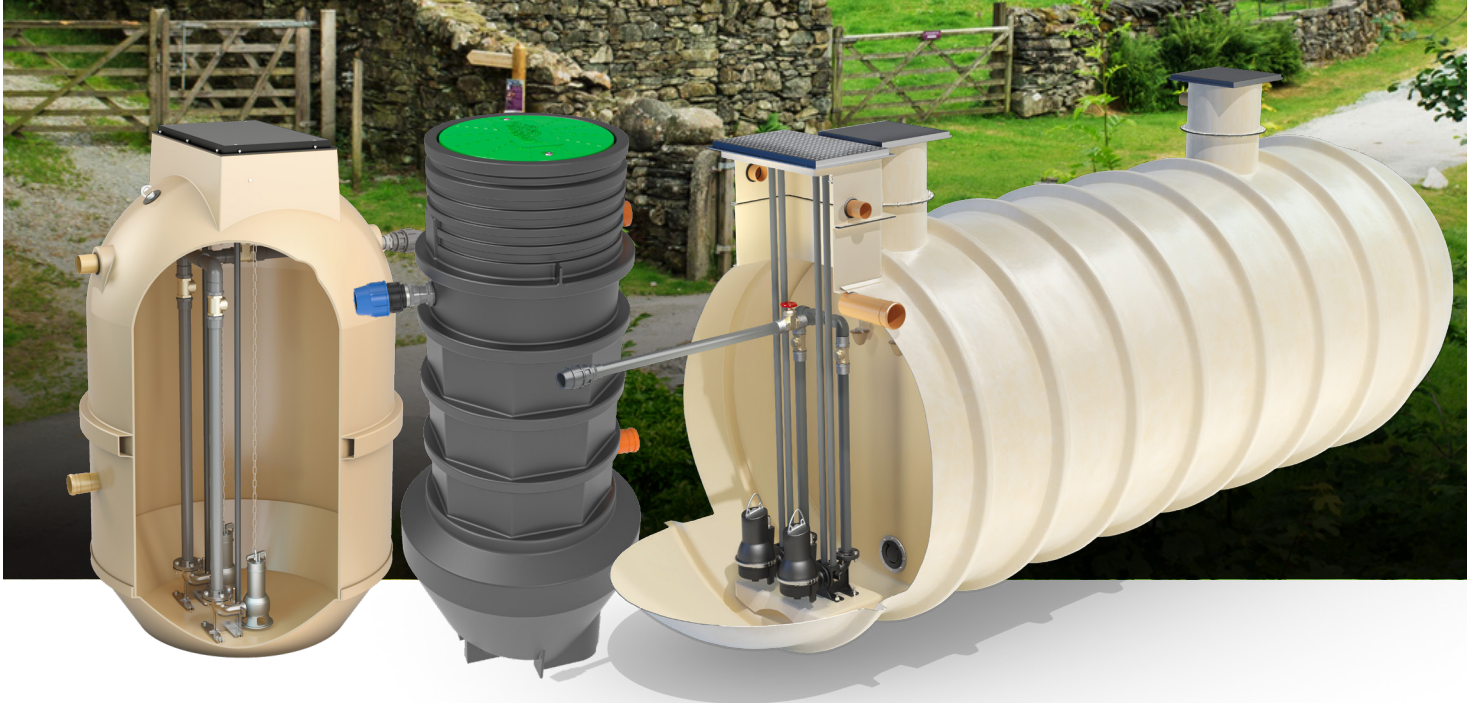

klargester.co.uk

Klargester Pumping Station Solutions

Experience



Trusted wastewater treatment solutions across a wide range of domestic and commercial applications.

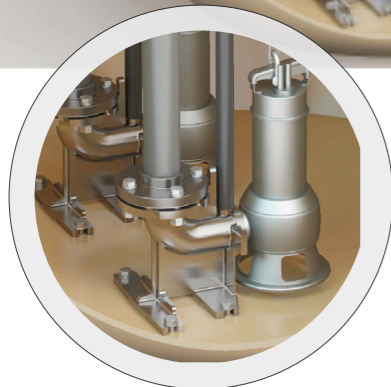

Typical Grundfos Pump

The Trusted Water Management Experts

About Klargester

Klargester have been leading specialists in the design and manufacture of an industry leading range of complete offmains wastewater management solutions for more than 68 years. Our dedicated technical team works closely with regulatory authorities and industry bodies to ensure total compliance in every component design and installation practice.

Providing solutions for all types of domestic, commercial or industrial build projects, the well-respected Klargester product range, includes sewage treatment plants, oil/water separators, packaged pumping stations and rainwater harvesting solutions.

Klargester Pumping Stations

If your domestic or commercial property is not connected to the sewer, or if it is below the sewer line, our range of Klargester pumping stations will take care of all your water, sewage and effluent.

The quality of our pumping station solutions is further enhanced by incorporating pumps supplied by Grundfos, the world's largest dedicated pump manufacturer. The Grundfos wastewater pumps used in Klargester products form part of a range that are all made with sustainability, long life and customer value at their core.

For expert advice, contact:
Email: klargesterkingspan.com
Tel: 01296 633 033

Why choose a Klargester Pumping Station solution?

Fully Compliant



Reliable, efficient, high quality pumping stations solutions.

Installed in thousands of domestic and commercial applications, the range of Klargester pumping stations provide easy to install and economical pumping solutions.

They are used in connection with sewage treatment plants, septic tanks, rainwater harvesting systems and surface water attenuation.

They are made with the highest quality materials and fittings and all are manufactured under the quality procedures of BS ISO 9001:2000 and HS ISO 18001, require little or no maintenance and, importantly, comply with Building Regulations Document H1 Foul Drainage and British Standards BS EN752, including options for 24-hour waste storage.

This product guide provides an overview of the solutions available and we are here to help in guiding you through the decision making process. Just get in touch to arrange a FREE site survey or to discuss your requirements in more detail with our technical experts, simply call 01296 633 033.



After Sales Service and Support.

We recognise the importance of after sales service and support and are proud of our nationwide Kingspan Service network, which comprises our Kingspan in-house Service team and Accredited Installer network in support of the Klargester Product Range.

With expertise across the entire Klargester product range, our local support networks provide the highest standards of after sales service and support you would expect from a global organisation including:

- First class technical engineering advice.
- Day to day technical support.
- 24 hour breakdown repair.
- Preventative maintenance plans.
- Installation and commissioning.
- Asset monitoring.
- Consultancy and advice.

For enquiries about any aspect of installation, commissioning or service simply contact:

Tel: 0333 240 6868
Email: helpingyou@kingspan.com



Typical Applications for Klargester Pumping Stations

Applications for Domestic Pumping Stations Range:

From basements to caravans, extensions to courtyards. If your property isn't connected to the sewer, or if it's below the sewer line, our pumping stations will take care of all your water, sewage and effluent.



Applications for Commercial Pumping Stations Range:

Whether you run a pub, shop or hotel, our range of commercial pumping stations make it easy to manage your sewage and wastewater, safely and efficiently.

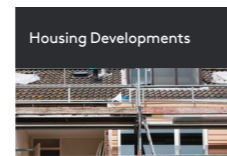
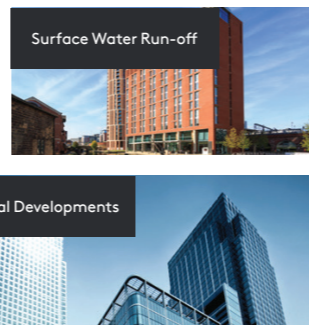

Klargester Malvern & Chiltern



Klargester Polyethylene pumping solutions ideal for small domestic properties from extensions to multiple units up to 10 residents, to comply with building regulations 24hr storage.

These solutions can be used in many other applications where sewage or surface water drainage cannot be connected via gravity. Our dedicated team is on hand to advise.

Product Benefits

- Prefabricated ready for installation with no man entry required
- High level alarm
- Internal lifting chains and guide rails (as specified)
- Wide range of pump options
- Various invert depths and positions
- Optional kiosks with warning beacons and optional telemetry systems



Technical Specification

	PE Pumps Chambers Technical Datasheet					
Tank Model	Tank Size (mm)	Capacity (Ltrs)	Tank Material	Control Panel	Alarm	Pump Type
Malvern	900 x 1,085	400	MDPE	Included	Included	Single/Twin
Malvern	900 x 1,690	620	MDPE	Included	Included	Single/Twin
Malvern	900 x 1,995	750	MDPE	Included	Included	Single/Twin
Chiltern	1,200 x 1,680	1,120	MDPE	Included	Included	Single/Twin
Chiltern	1,200 x 2,000	1,300	MDPE	Included	Included	Single/Twin
Chiltern	1,200 x 2,600	1,600	MDPE	Included	Included	Single/Twin

*Subject to be commissioned & serviced by Kingspan Service or Accredited Installer.

Klargester Mendip / Pennine / Bowfell



Klargester vertical pumping solutions are ideal for commercial developments and premises, where drainage by gravity is not an option.

Manufactured from robust GRP, Klargester vertical pumping stations are designed as a single piece chamber, ready for installation with no man entry required.

Available in a range of sizes and suitable for commercial applications from small roof run offs, to large SuDS schemes, Klargester vertical pumping stations deliver up to 70 litres/second and have a 24 hours storage capacity for foul waste to comply with Building Regulations.

Product Benefits

- High level alarm
- Internal lifting chains and guide rails (as specified)
- Wide range of pump options
- Range of emergency overflow tanks, if required
- Inlet connection sizes to suit site
- Various invert depths and positions
- GRP chambers with internal pipework in plastic, galvanised or cast iron
- Optional kiosks with warning beacons and optional telemetry systems

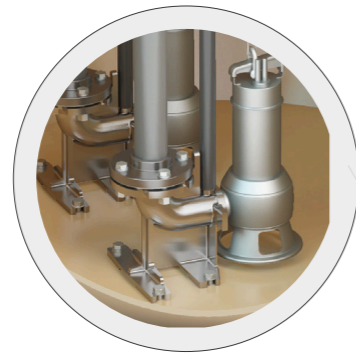

Typical Grundfos Pump

Technical Specification

Vertical Pump Chambers Technical Datasheet						
Tank model	Vertical Tank Size (mm)	Capacity (Ltrs)	Tank Material	Control Panel	Alarm	Pump Type
Mendip	1,250 Diameter	4,900	GRP	Included	included	Single/Twin
Pennine	1,800 Diameter	10,000*	GRP	Included	included	Single/Twin
Bowfell	2,800 Diameter	22,000*	GRP	Included	included	Single/Twin

*maximum

Klargester Cairngorm / Nevis

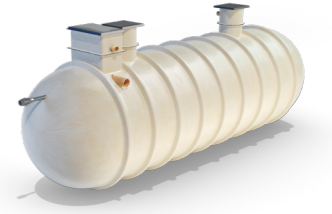

The Klargester Horizontal Range is engineered for reliable performance offering complete peace of mind.

If your power supplies fail this commercial package pumping station will respond quickly and separate your liquids and solids into a different chamber, allowing you to store the waste for up to 24 hours. When your power comes back online, the pumps will resume normal operation.

Product Benefits

- Two options available, including a 1.8m and 2.8m diameter tank sizes
- Separate wet well and storage sections
- Easy and simple on-site installation
- Completely sealed system
- Comprehensive alarms for complete peace of mind
- Less crange and shallower excavation than concrete pumping stations
- Multiple invert options
- Single-tank installation from 8-79m³

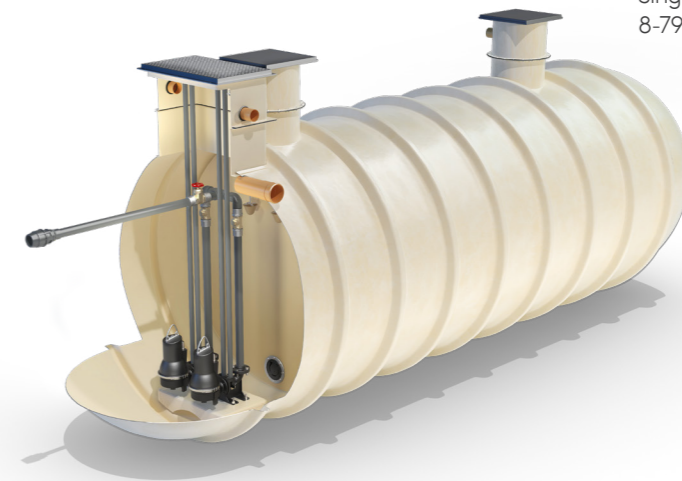

Technical Specification

Horizontal Pump Chambers Technical Datasheet						
Tank Model	Tank Size (mm)	Capacity (Ltrs)	Tank Material	Control Panel	Alarm	Pump Type
Cairngorm	1,800 Diameter	8000 - 29,000	GRP	Included	Included	Single/Twin
Nevis	2,800 Diameter	18,000 - 79,000	GRP	Included	Included	Single/Twin

Selecting the Correct Pumping Station

Free expert advice at every stage.

All Klargester pumping stations are suitable for pumping wastewater effluent and sewage in accordance with BS 756-2. They are also designed in line with Building Regulations for Foul Drainage.

System size requirements will depend on the type of waste you need to manage, distance from the sewer and the difference in levels.

The Klargester pumping station range will require less craneage and shallower excavations than concrete pumping systems and there is no need for anyone to enter the tank during excavation and installation.

Prior to installation, there is a legal requirement to obtain permission from the appropriate agencies (including connection to a public sewer).

For expert advice, to help you select the correct system, please contact our specialist team on **01296 633 033** or email klargester@kingspan.com

The key factors to size your system are as follows:

- Application: domestic, residential or commercial
- Material application: sewage, effluent or surface water.
- Inlet depth (below ground level).
- Pumping distance and lift.
- Electrical supply.

Sizing Chart



Please use the chart below to help correctly size and select your Klargester Pumping Station solution.

Pumping Distance (A)	Meters
Pumping Lift (B)	Meters
Discharge Height (C) (if different to Lift)	Meters
Proposed Inlet Depth (D)	Meters
Inlet Size	110mm <input type="checkbox"/> 160mm <input type="checkbox"/>
Type of Application ie. 1 House, 2 Houses , pub, etc	
Number of Users	
Material Application	Sewage <input type="checkbox"/> Surface Water <input type="checkbox"/> Effluent <input type="checkbox"/> Flow rate* (if known): <input type="text"/> Drainage area* (if known): <input type="text"/> <small>*Only applicable to Surface Water</small>
Power Supply	Single <input type="checkbox"/> Three Phase <input type="checkbox"/>
New Lay or Existing Rising Main	New <input type="checkbox"/> Existing <input type="checkbox"/>
If Existing - Size of Rising Main	
Pumping to: Public/Private Sewer, Treatment Plant, etc.	
24 Hours Storage Required	Yes <input type="checkbox"/> No <input type="checkbox"/>



Contact Details

UK

Klargester

College Road North
Aston Clinton | Aylesbury
Buckinghamshire | HP22 5EW

T: +44 (0) 1296 633 000

F: +44 (0) 1296 633 001

E: klargest@kingspan.com

www.kingspan.co.uk/klargest

We take every care to ensure that the information in this document is accurate at the point of publication. Specification may vary (within a small parameter) due to manufacturing process variations or environmental conditions. All images are for illustration purposes only and should not be taken as binding. The actual product may vary, and specification/dimensions/colour/other attributes may differ.

To ensure you are viewing the most recent and accurate product information, please visit this link:

<https://www.kingspan.com/gb/en/products/water-management/pumping-stations/>

©Kingspan and the Lion Device are Registered Trademarks of the Kingspan Group in the UK, Ireland and other countries. All rights reserved. Registered in Country No.NI017631. Registered Office: 180 Gilford Road, Portadown, Co. Armagh, BT635LF. VAT GB412 5124 03