

Internal Central Division

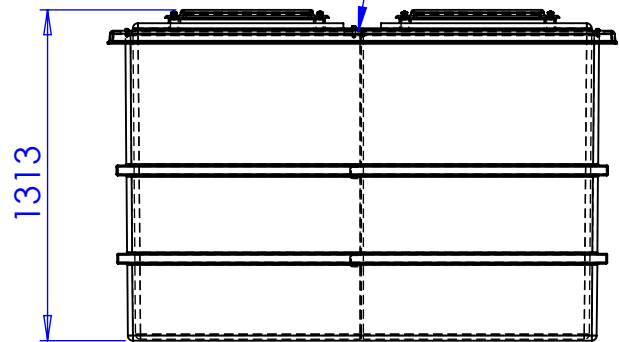

40mm Encapsulated Steel Braces

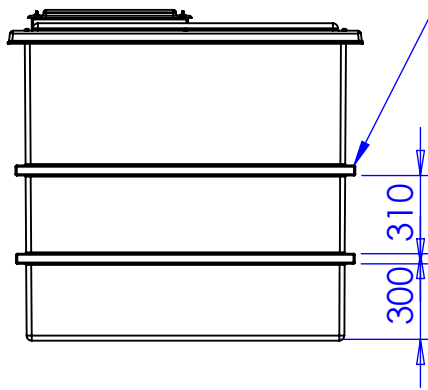

TITLE  
PW2726.DIV.AG - TD

**NOTE:**  
All tanks must be fully supported on a flat, level & continuous foundation providing structural support to the tank when full to maximum operating capacity. It is essential that the user refers to the conditions of installation document prior to the installation of the tank. Under no circumstances should the tank body be used to provide support to pipework and ancillary items. The tank lid is a structural part of the tank and must be in place and fitted correctly when water is contained within the tank.

DESCRIPTION:  
PW2726.DIV.AG - TD  
PW2726.DIV One piece divided cold water storage tank AG Air Gap

TANK SPECIFICATION :	
INTERNAL DIMENSIONS	1828mm x 1220mm x 1220mm
EXTERNAL DIMENSIONS	2020mm x 1410mm x 1313mm
NOM. CAPACITY	2726 Litres
DRY WEIGHT	xxx KG
INSULATION THICKNESS	25mm
MATERIAL	GRP

DRAWN BY  
D.PRYJMACHUK

DATE  
03/10/2024

SCALE:1:30 SHEET 1 OF 1

