

Internal Central Divider

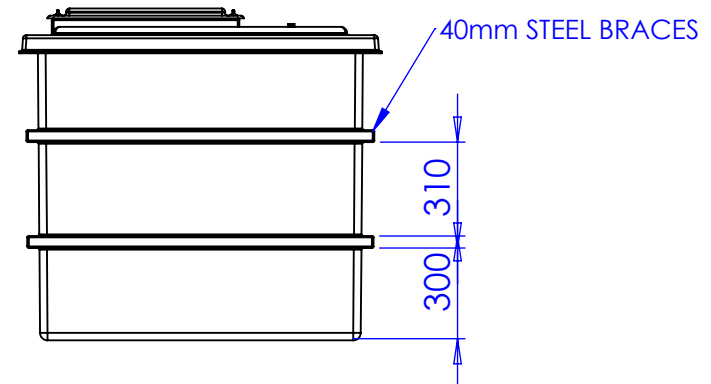
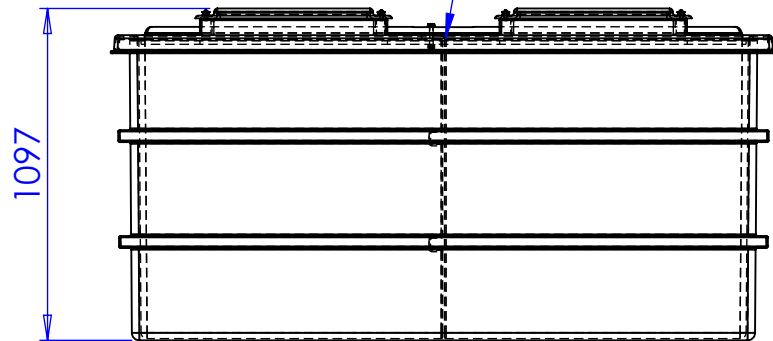

TITLE  
PW2000.DIV.AG - TD

DRAWN BY  
D.PRYJMACHUK

DATE  
09/10/2024

**NOTE:**  
All tanks must be fully supported on a flat, level & continuous foundation providing structural support to the tank when full to maximum operating capacity. It is essential that the user refers to the conditions of installation document prior to the installation of the tank. Under no circumstances should the tank body be used to provide support to pipework and ancillary items. The tank lid is a structural part of the tank and must be in place and fitted correctly when water is contained within the tank.

DESCRIPTION:  
PW2000.DIV.AG - TD  
PW2000 Divided cold water storage tank suitable for an AG/AF Air gap

TANK SPECIFICATION :	
INTERNAL DIMENSIONS	2000 x 1000 x 1000mm
EXTERNAL DIMENSIONS	2200 x 1200 x 1097mm
NOM. CAPACITY	2000 Litres
DRY WEIGHT	xxx KG
INSULATION THICKNESS	25mm
MATERIAL	GRP

