

INTERNAL CENTRAL DIVISION

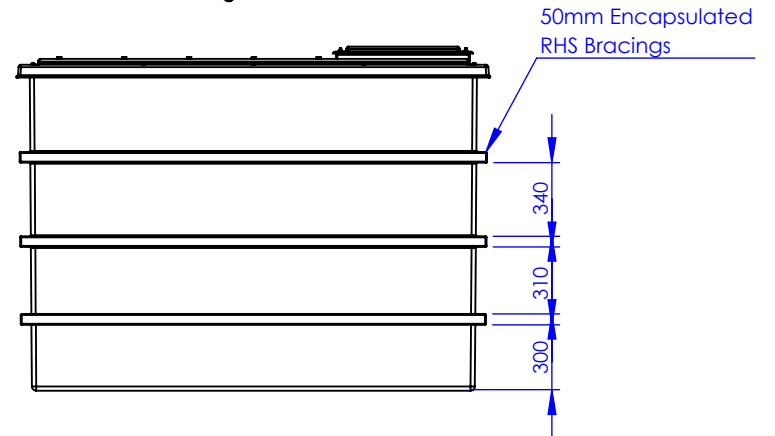
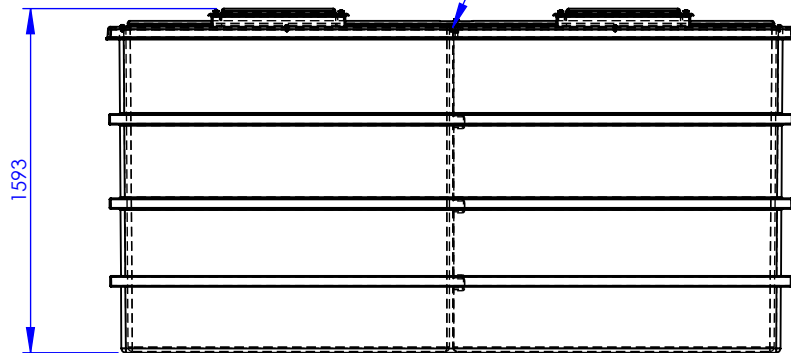

TITLE
PW9000.DIV.AG - TD

DRAWN BY
D.PRYJMACHUK

DATE
09/10/2024

NOTE:
All tanks must be fully supported on a flat, level & continuous foundation providing structural support to the tank when full to maximum operating capacity. It is essential that the user refers to the conditions of installation document prior to the installation of the tank. Under no circumstances should the tank body be used to provide support to pipework and ancillary items. The tank lid is a structural part of the tank and must be in place and fitted correctly when water is contained within the tank.

DESCRIPTION:
PW9000.DIV.AG - TD
Divided cold water storage tank suitable for an AG/AF Air gap

TANK SPECIFICATION :

INTERNAL DIMENSIONS	3000 x 2000 x 1500mm
EXTERNAL DIMENSIONS	3192 x 2192 x 1593mm
NOM. CAPACITY	9000 Litres
DRY WEIGHT	xxx KG
INSULATION THICKNESS	25mm
MATERIAL	GRP

