



VARI-RS BOOSTER SET

(FEATURING GRUNDFOS PUMPS)



VARI-RS BOOSTER SET APPLICATIONS

Designed for cold water boosting in a
variety of applications

- Commercial Sites
- Multiple Residential Properties
- Industrial Sites
- Agricultural & Farming
- Manufacturing

PRODUCT OVERVIEW

The Vari-RS cold water booster set is designed to be a high-performance solution that is available in single, twin, and triple pump configuration.

The system comes with intuitive variable speed frequency inverters mounted directly to the pump motor.

The Vari-RS is fully WRAS and KUKREG4 approved to meet U.K. REG4 guidelines, as well as the most demanding applications.

The system includes advanced features such as fault signals, error code displays, and a range of BMS connections.

PRODUCT FEATURES

- Flow rate of up to 495 l/m (mid-curve)
- Head pressure of up to 7.5 bar
- Pumps supplied/manufactured by Grundfos
- Single, twin, or triple pump options
- Fully WRAS and KUKREG4 approved
- Air-cooled variable speed inverter(s)
- Digital display for fault diagnostics
- High efficiency motors
- BMS volt free contacts
- Dry run protection
- BMS Connections available
- Fully wet and pressure tested

SYSTEM RANGE PERFORMANCE

Pump Configuration	Single, Twin, Triple
Flow Range (Mid-curve)	50 - 495 l/m
Pressure Range	1.5 - 7.5 bar
Max System Pressure	9.0 bar
Inverter Type	Motor-mounted
Max System Temp	40 °C

OPTIONAL COMPONENTS

We provide a range of optional equipment that can be paired with your Vari-RS booster set: -

- WRAS approved GRP water chambers
- MDPE water chambers
- Professional control panels
- Anti-vibration feet
- Pipework and fittings
- Backup parts and materials
- GRP pump enclosures
- Combination units
- Commissioning and Service

8L WRAS APPROVED
EXPANSION VESSELS

STAINLESS STEEL
MANIFOLD

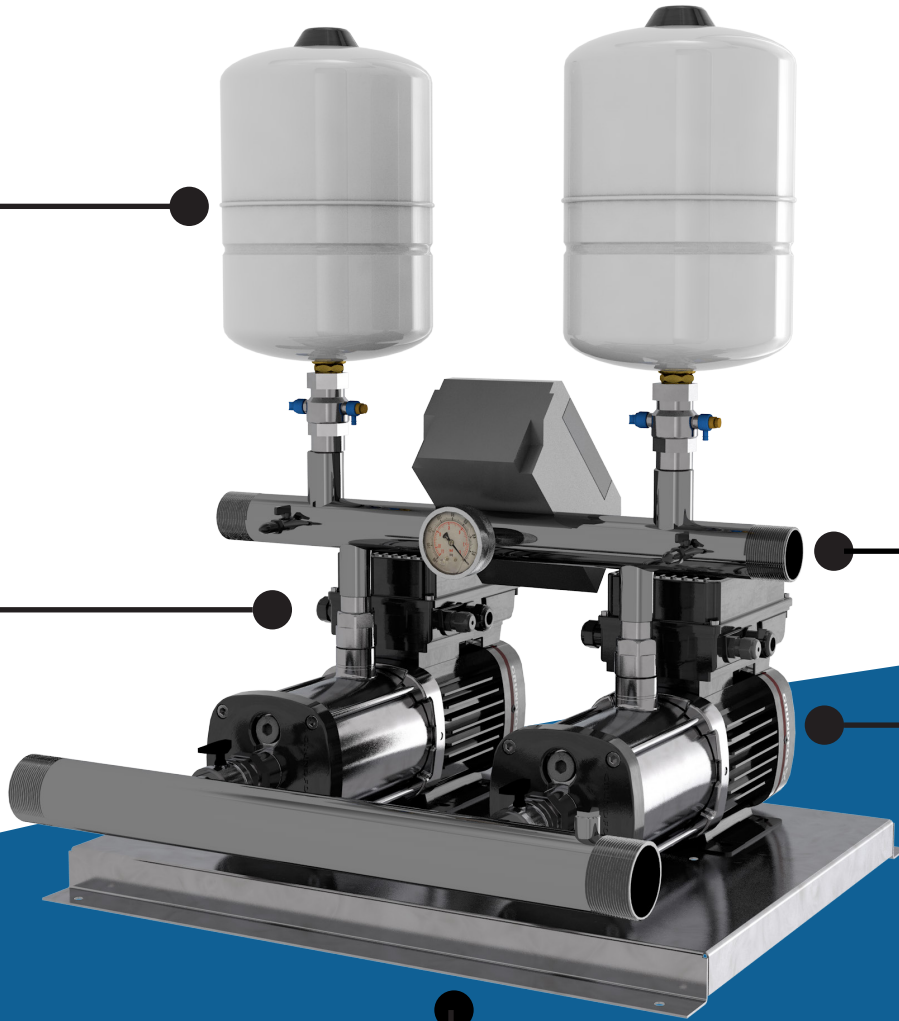

Model Shown: Twin Vari-RS 2RS3-5/8/GF

VARIABLE SPEED
INVERTERS

COMPACT FOOTPRINT

MULTI STAGE
PUMPS



SINGLE VARI-RS BOOSTER SET

The Single Vari-RS booster set is a compact and cost-effective cold water booster set that is ideal for residential and light commercial installations.

The single Vari-RS system comprises of a single horizontal multi-stage pump and an air-cooled variable speed frequency inverter with intuitive LCD interface.

The system includes a range of advanced features such as fault signals and an error code display as standard

PRODUCT FEATURES

- Flow rate of up to 165 l/m (mid-curve)
- Head pressure of up to 7,5 bar
- Fully WRAS and KUKREG4 approved
- Dry run protection
- Advanced variable speed inverter
- Glycerine filled pressure gauge
- Stainless steel fittings
- In-stock - immediate delivery

FLOW RATES AND PRESSURES

Model Ref	Mid-curve Duty	
	(Flow l/m)	Pressure (bar)
1RS3-2/8/GF	42	1.8
1RS3-5/8/GF	42	3.8
1RS3-6/8/GF	42	4.8
1RS3-7/8/GF	42	5.5
1RS3-8/8/GF	42	6.2
1RS5-2/8/GF	66	1.5
1RS5-5/8/GF	66	4.2
1RS5-7/8/GF	66	6.0
1RS5-8/8/GF	66	6.5
1RS5-9/8/GF	66	7.5
1RS10-2/8/GF	165	2.5
1RS10-3/8/GF	165	3.8

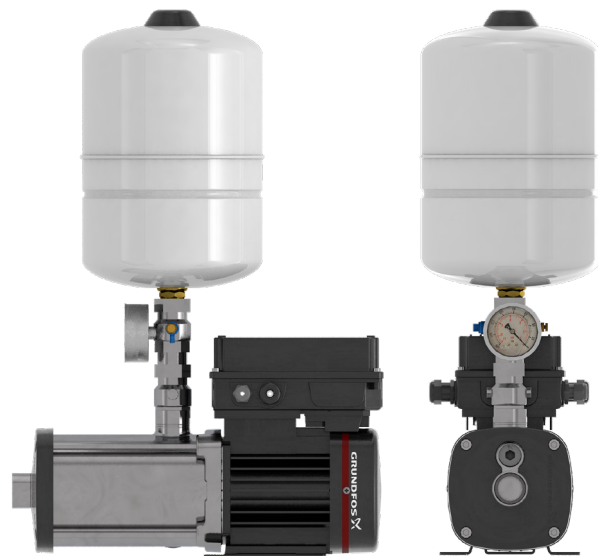

SYSTEM OPERATION

The Single Vari-RS cold water booster set uses the RS variable speed inverter that is installed onto the Motor Connection Box. The inverter regulates the rotational speed of the pump using the electrical frequency.

CERTIFICATIONS

Each Vari-RS system conforms to the latest U.K. standards set by the water regulation authority and comes with a range of industry certifications:-



DELIVERY & AVAILABILITY

The Vari-RS single booster set can be delivered in as little as 24 hours. This is a stocked product and as such, are always available at short notice.

PUMP DIAGRAM

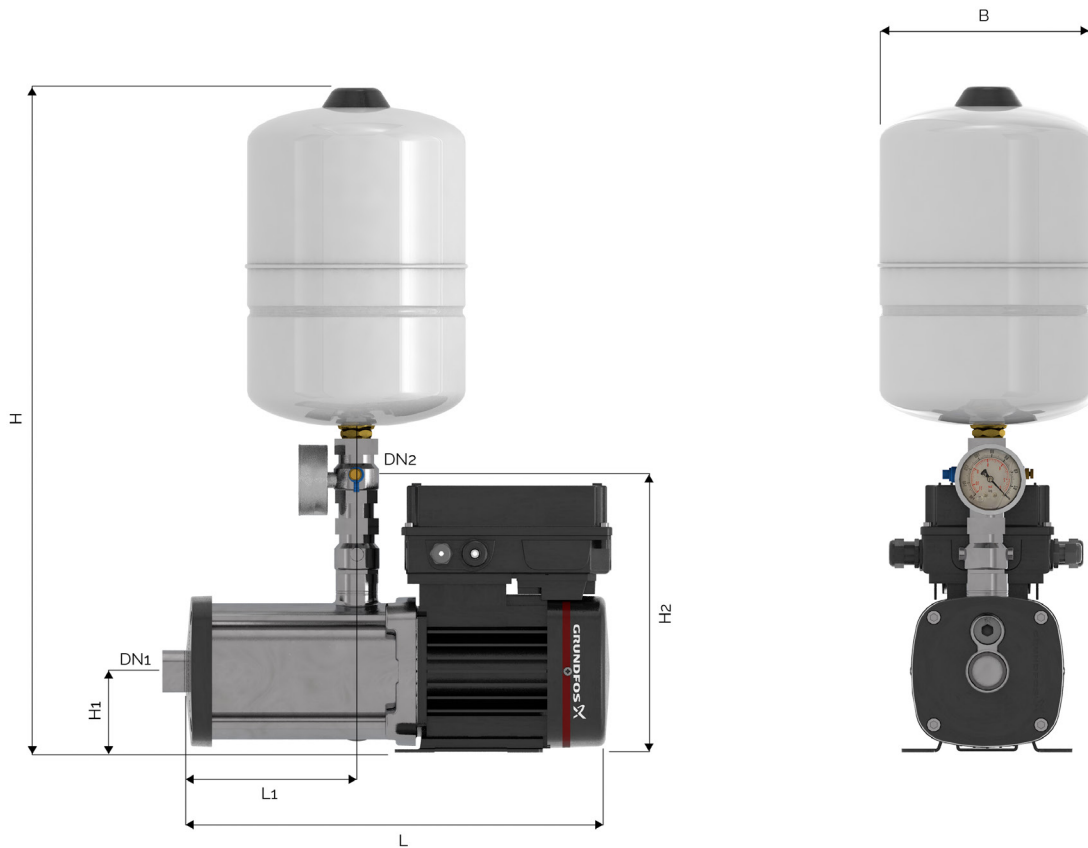

DIMESNSIONS AND POWER

Model Ref	DN1	DN2	B	H	H1	L	Per Pump			
							Power Supply	kW	HP	FLC
1RS3-2/8/GF	1"	1"	300	900	135	609	240v	0.46	0.6	1.2
1RS3-5/8/GF	1"	1"	300	900	135	656	240v	0.6	0.8	1.5
1RS3-6/8/GF	1"	1"	300	900	135	680	240v	0.65	0.9	1.72
1RS3-7/8/GF	1"	1"	300	900	135	704	240v	1.1	1.4	2.6
1RS3-8/8/GF	1"	1"	300	900	135	728	240v	1.1	11.4	2.6
1RS5-2/8/GF	1 ¼"	1"	300	900	135	608	240v	0.46	0.6	1.2
1RS5-5/8/GF	1 ¼"	1"	300	900	135	656	240v	1.1	1.4	2.6
1RS5-7/8/GF	1 ¼"	1"	300	900	135	704	240v	2.2	2.9	3.3
1RS5-8/8/GF	1 ¼"	1"	300	900	135	728	240v	2.2	2.9	3.3
1RS5-9/8/GF	1 ¼"	1"	300	900	135	728	240v	2.2	2.9	3.3
1RS10-2/8/GF	1 ½"	1 ¼"	300	900	135	627	240v	1.5	1	3.3
1RS10-3/8/GF	1 ½"	1 ¼"	300	900	135	689	240v	2.2	2.9	4.6

TWIN VARI-RS BOOSTER SET

The Twin Vari-RS booster set is a compact and cost-effective cold water booster set that is ideal for residential and light commercial installations.

The Twin Vari-RS booster system features dual horizontally mounted multi-stage pumps and air-cooled variable speed frequency inverters with intuitive interface.

The system includes a range of advanced features such as fault signals and an error code display as standard

PRODUCT FEATURES

- Flow rate of up to 330 L/m (mid-curve)
- Head pressure of up to 7,5 bar
- Fully WRAS and KUKREG4 approved
- Dry run protection
- Advanced variable speed inverters
- Glycerine filled pressure gauge
- Stainless steel fittings
- In-stock - immediate delivery

FLOW RATES AND PRESSURES

Model Ref	Mid-curve Duty	
	(Flow L/m)	Pressure (bar)
2RS3-2/8/GF	84	1.8
2RS3-5/8/GF	84	3.8
2RS3-6/8/GF	84	4.8
2RS3-7/8/GF	84	5.5
2RS3-8/8/GF	84	6.2
2RS5-2/8/GF	132	1.5
2RS5-5/8/GF	132	4.2
2RS5-7/8/GF	132	6.0
2RS5-8/8/GF	132	6.5
2RS5-9/8/GF	132	7.5
2RS10-2/8/GF	330	2.5
2RS10-3/8/GF	330	3.8

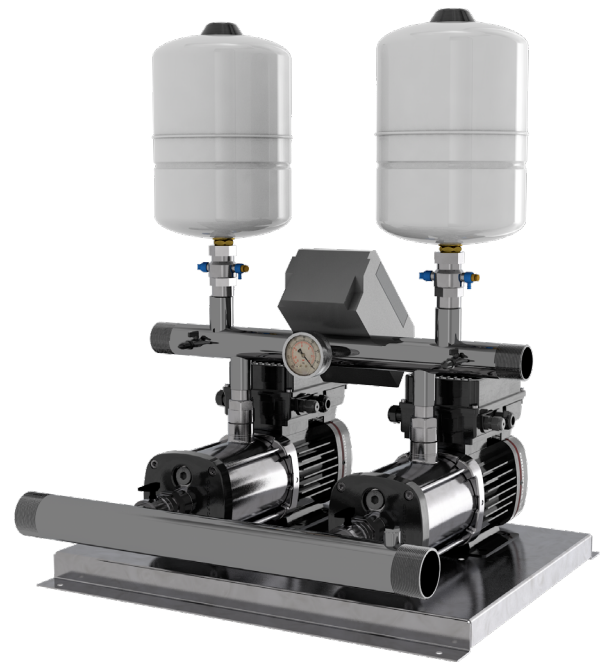

SYSTEM OPERATION

The Twin Vari-RS cold water booster set uses the RS variable speed inverter that is installed onto the Motor Connection Box. The inverter regulates the rotational speed of the pump using the electrical frequency.

CERTIFICATIONS

Each Vari-RS system conforms to the latest U.K. standards set by the water regulation authority and comes with a range of industry certifications:-



DELIVERY & AVAILABILITY

The Vari-RS twin booster set can be delivered in as little as 48 hours. This is a stocked product and as such, are always available at short notice.

PUMP DIAGRAM

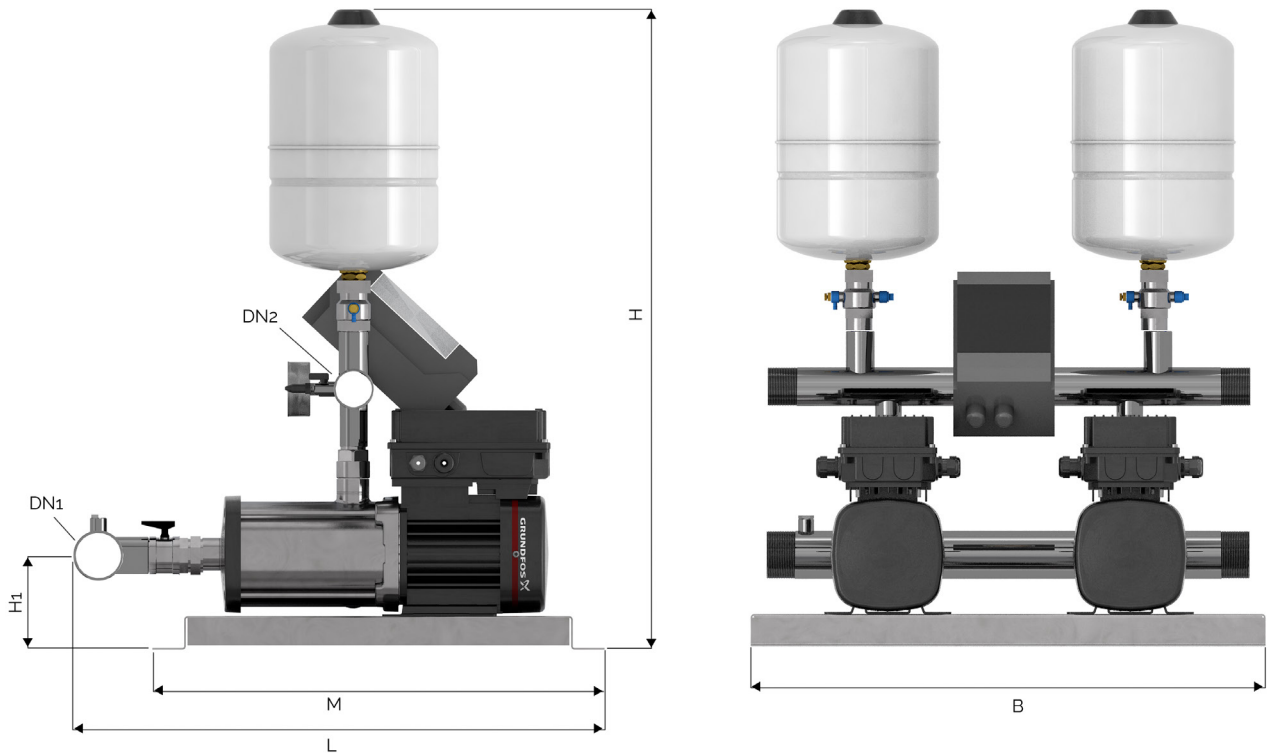

DIMENSIONS AND POWER

Model Ref	DN1	DN2	B	H	H1	L	M	Per Pump			
								Power Supply	kW	HP	FLC
2RS3-2/8/GF	2"	1 ½"	640	900	135	609	540	240V	0.46	0.6	1.2
2RS3-5/8/GF	2"	1 ½"	640	900	135	656	540	240V	0.6	0.8	1.5
2RS3-6/8/GF	2"	1 ½"	640	900	135	680	540	240V	0.65	0.9	1.72
2RS3-7/8/GF	2"	1 ½"	640	900	135	704	540	240V	1.1	1.4	2.6
2RS3-8/8/GF	2"	1 ½"	640	900	135	728	540	240V	1.1	11.4	2.6
2RS5-2/8/GF	2"	1 ½"	640	900	135	608	540	240V	0.46	0.6	1.2
2RS5-5/8/GF	2"	1 ½"	640	900	135	656	540	240V	1.1	1.4	2.6
2RS5-7/8/GF	2"	1 ½"	640	900	135	704	540	240V	2.2	2.9	3.3
2RS5-8/8/GF	2"	1 ½"	640	900	135	728	540	240V	2.2	2.9	3.3
2RS5-9/8/GF	2"	1 ½"	640	900	135	728	540	240V	2.2	2.9	3.3
2RS10-2/8/GF	2 ½"	2"	640	900	135	627	540	240V	1.5	1	3.3
2RS10-3/8/GF	2 ½"	2"	640	900	135	689	540	240V	2.2	2.9	4.6

TRIPLE VARI-RS BOOSTER SET

The Triple Vari-RS booster set is a compact and cost-effective cold water booster set that is ideal for residential and light commercial installations.

The Triple Vari-RS system features three horizontal mounted multi-stage pumps and three air-cooled variable speed frequency inverters with intuitive interface.

The system includes a range of advanced features such as fault signals and an error code display as standard

PRODUCT FEATURES

- Flow rate of up to 495 l/m (mid-curve)
- Head pressure of up to 7.5 bar
- Fully WRAS and KUKREG4 approved
- Dry run protection
- Advanced variable speed inverters
- Glycerine filled pressure gauge
- Stainless steel fittings
- In-stock - immediate delivery

FLOW RATES AND PRESSURES

Model Ref	Mid-curve Duty	
	(Flow l/m)	Pressure (bar)
3RS3-2/8/GF	126	1.8
3RS3-5/8/GF	126	3.8
3RS3-6/8/GF	126	4.8
3RS3-7/8/GF	126	5.5
3RS3-8/8/GF	126	6.2
3RS5-2/8/GF	198	1.5
3RS5-5/8/GF	198	4.2
3RS5-7/8/GF	198	6.0
3RS5-8/8/GF	198	6.5
3RS5-9/8/GF	198	7.5
3RS10-2/8/GF	495	2.5
3RS10-3/8/GF	495	3.8

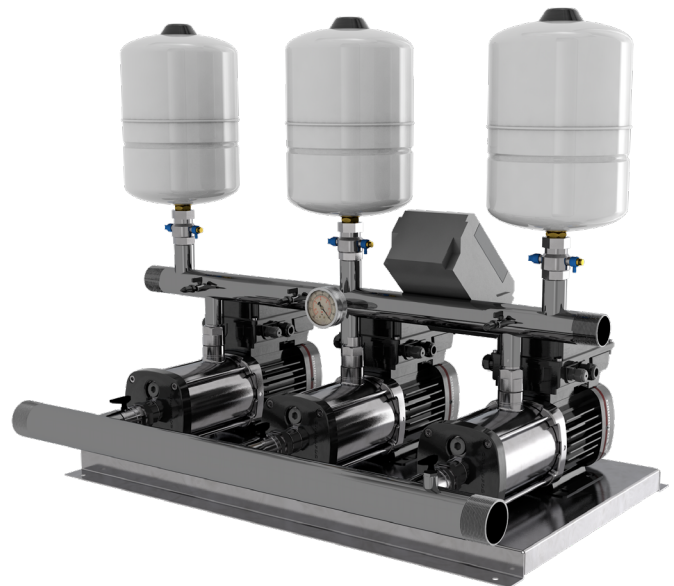

SYSTEM OPERATION

The Triple Vari-RS cold water booster set uses the RS variable speed inverters that are installed onto the Motor Connection Box. The inverters regulate the running speed of the pumps by using electrical frequency of the pump.

CERTIFICATIONS

Each Vari-RS system conforms to the latest U.K. standards set by the water regulation authority and comes with a range of industry certifications:-



DELIVERY & AVAILABILITY

The Vari-RS triple booster set can be delivered in as little as 48 hours. This is a stocked product and as such, are always available at short notice.

PUMP DIAGRAM

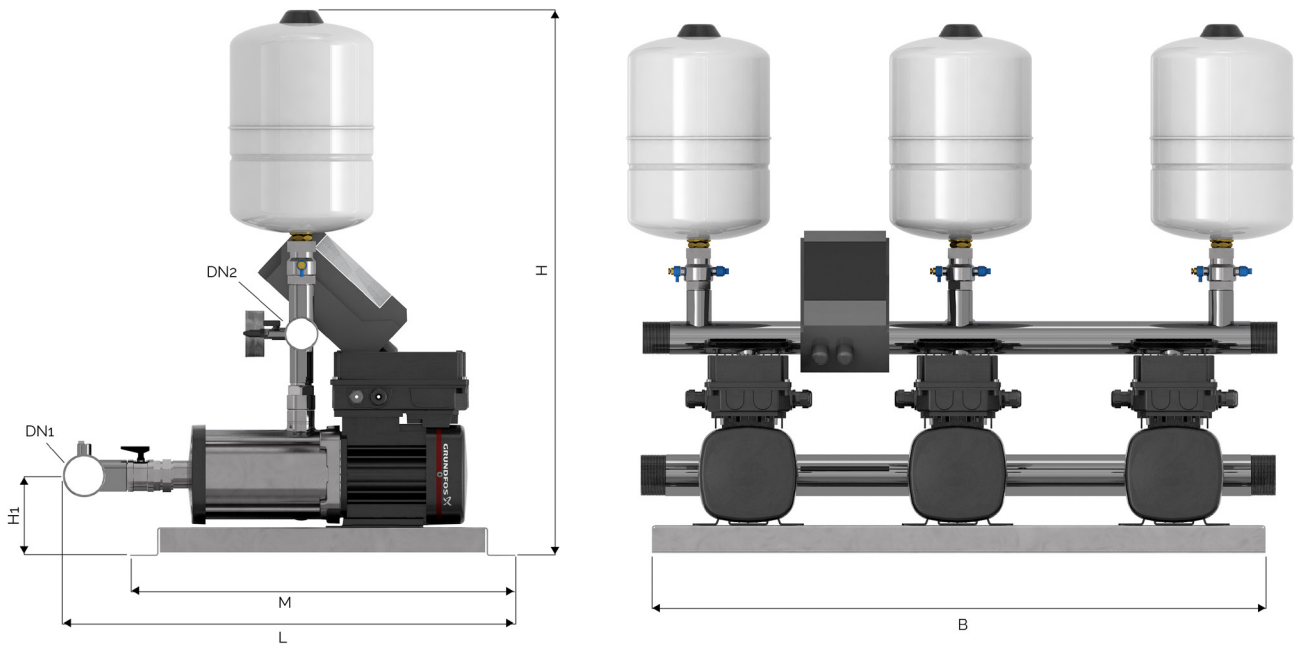

DIMENSIONS AND POWER

Model Ref	DN1	DN2	B	H	H1	L	M	Per Pump			
								Power Supply	kW	HP	FLC
3RS3-2/8/GF	2 ½"	2"	900	920	135	676	540	240v	0.46	0.6	1.2
3RS3-5/8/GF	2 ½"	2"	900	920	135	725	540	240v	0.6	0.8	1.5
3RS3-6/8/GF	2 ½"	2"	900	920	135	760	540	240v	0.65	0.9	1.72
3RS3-7/8/GF	2 ½"	2"	900	920	135	934	540	240v	1.1	1.4	2.6
3RS3-8/8/GF	2 ½"	2"	900	920	135	858	540	240v	1.1	11.4	2.6
3RS5-2/8/GF	2 ½"	2"	900	920	135	608	540	240v	0.46	0.6	1.2
3RS5-5/8/GF	2 ½"	2"	900	920	135	656	540	240v	1.1	1.4	2.6
3RS5-7/8/GF	2 ½"	2"	900	920	135	680	540	240v	2.2	2.9	3.3
3RS5-8/8/GF	2 ½"	2"	900	920	135	704	540	240v	2.2	2.9	3.3
3RS5-9/8/GF	2 ½"	2"	900	920	135	728	540	240v	2.2	2.9	3.3
3RS10-2/8/GF	2 ½"	2"	900	920	135	689	540	240v	1.5	1	3.3
3RS10-3/8/GF	2 ½"	2"	900	920	135	686	540	240v	2.2	2.9	4.6

PUMP SPECIFICATIONS

Pump Specifications		
Liquid Handled	Type of Liquid	Water, moderate solutions, glycol, viscous fluids
	Temperature	min - 20 Max + 120 °C
	Max Chlorine Content	500 ppm
	Max Working Pressure [Mpa]	1
Construction	Impeller	Closed centrifugal type
	Motor Bearings	Screened ball bearing - Greased for life
Pipe Connection	Suction	1" ½ UNI ISO 228
	Discharge	1" ¼ UNI ISO 228
Material	Casing	EN 1.4301 (AISI 304)
	Impeller	EN 1.4301 (AISI 304)
	Intermediate Casing	EN 1.4301 (AISI 304)
	O-rings	EPDM
	Shaft Seal	Ceramic / Carbon / EPDM
	Liner Ring	EN 1.4301 (AISI 304) + PPS
	Casing Cover	EN 1.4301 (AISI 304)
	Shaft	EN 1.4301 (AISI 304) wet extension
	Bracket	EN AB-AISI11Cu2 (Fe)(Die cast Aluminium)
	Applicable to standard of test	ISO 9906:2012 - Grade 3B

MOTOR SPECIFICATIONS

Motor Specifications	
Type	Electric - TEFC Single Phase
Efficiency Level (Reg. 1781/2019)	IE3
No. of Poles	2
Rotation Speed	2890 - 2901
Insulation Class	F
Max Temperature Environment	40 Degrees C
Protection Degree (CEI EN 60034-5)	IP55
Power Rating Kw	0.45 ÷ 2.2
Power Rating HP	0.6 ÷ 3.0
Frequency Hz	50
Voltage	230 +10%
Capacitor	Built-in
Overload Protection	Built-in
Casing Material	Aluminium
Base Material / Motor Support	Aluminium
Dimensions of Cable Entry	PG11 - M20X1/5

1RS3-2/8/GF - 2RS3-2/8/GF - 3RS3-2/8/GF PUMP CURVE

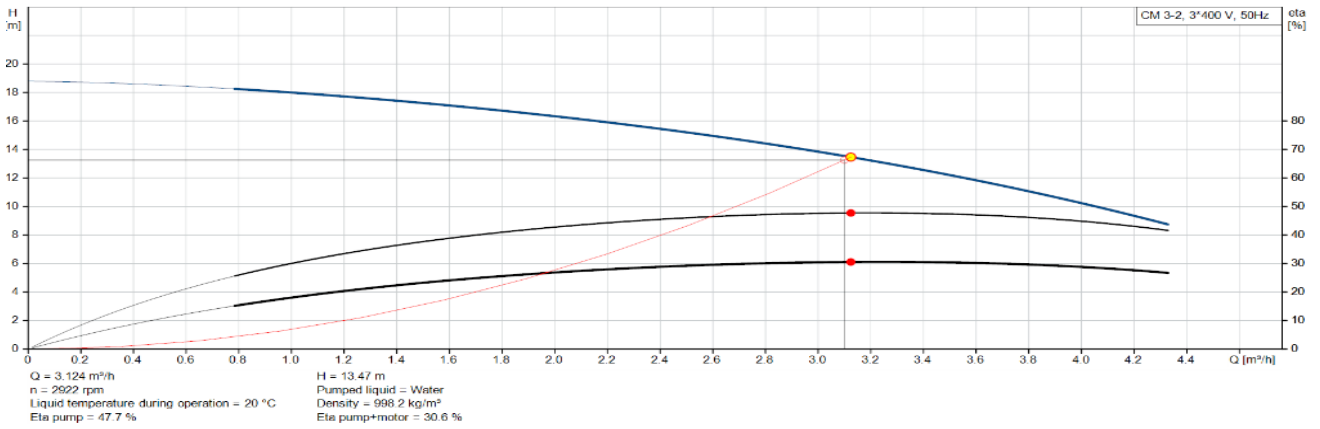

1RS3-5/8/GF - 2RS3-5/8/GF - 3RS3-5/8/GF PUMP CURVE

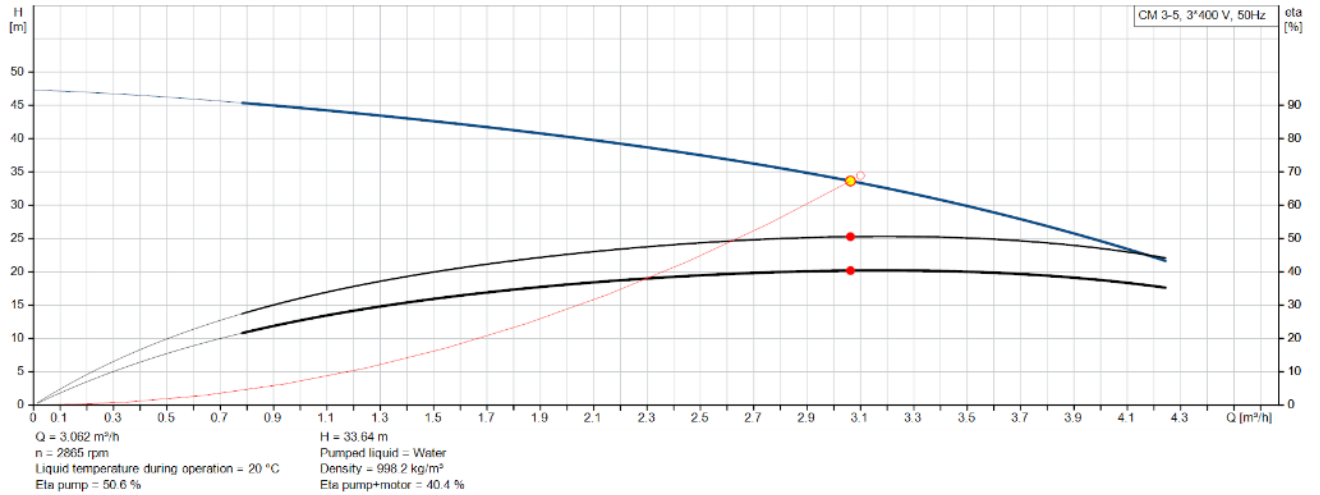

1RS3-6/8/GF - 2RS3-6/8/GF - 3RS3-6/8/GF PUMP CURVE

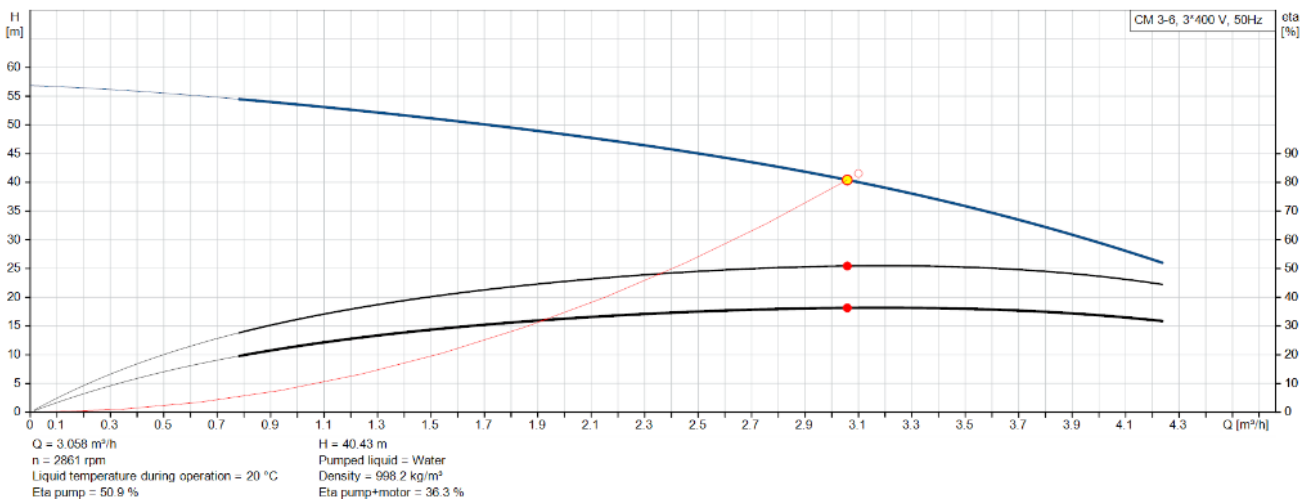

1RS3-7/8/GF - 2RS3-7/8/GF - 3RS3-7/8/GF PUMP CURVE

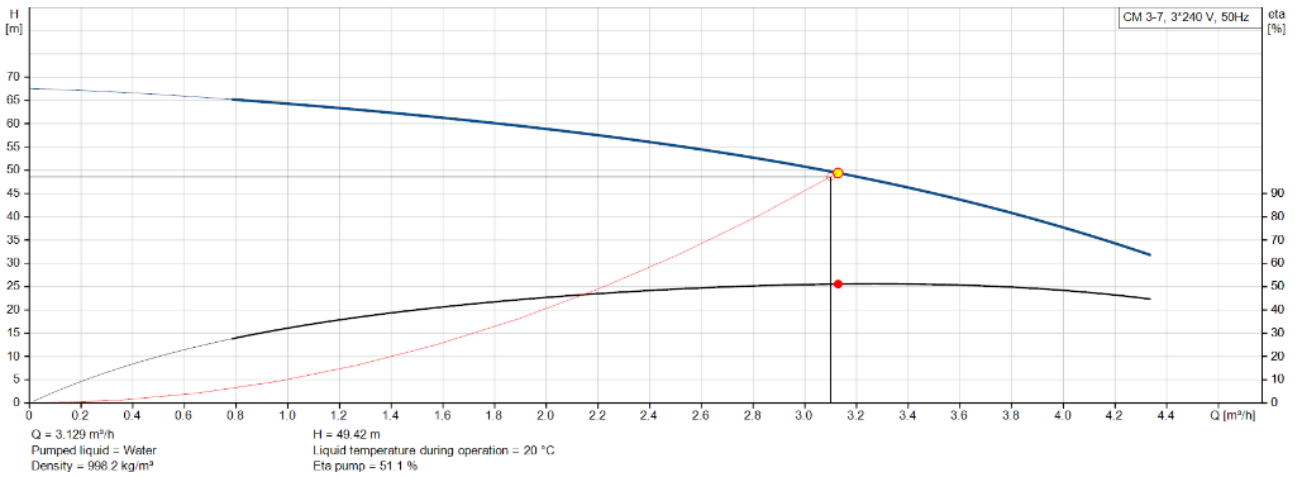

1RS3-8/8/GF - 2RS3-8/8/GF - 3RS3-8/8/GF PUMP CURVE

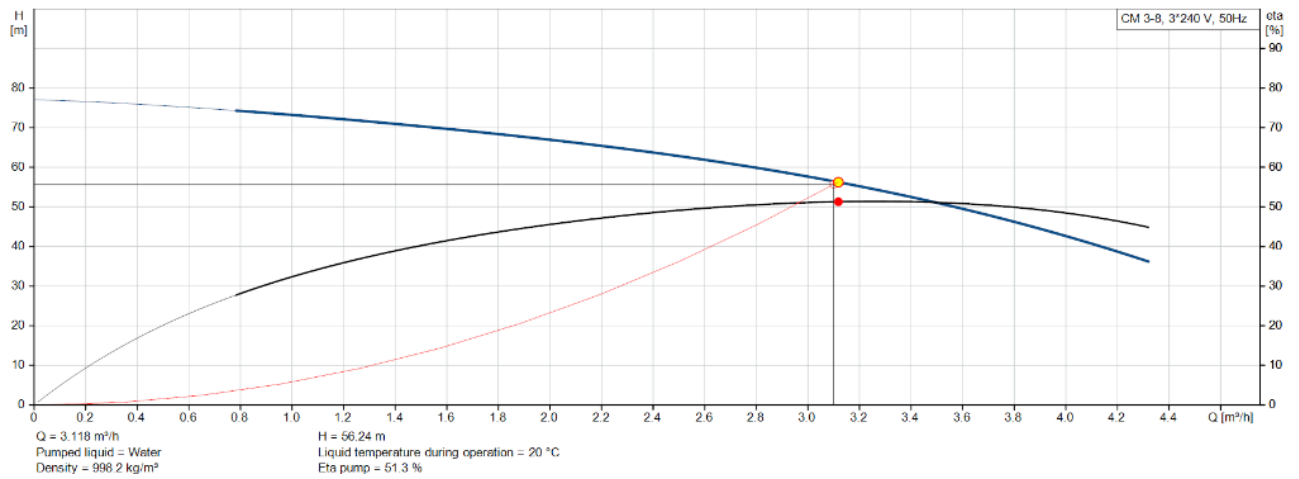

1RS5-2/8/GF - 2RS5-2/8/GF - 3RS5-2/8/GF PUMP CURVE

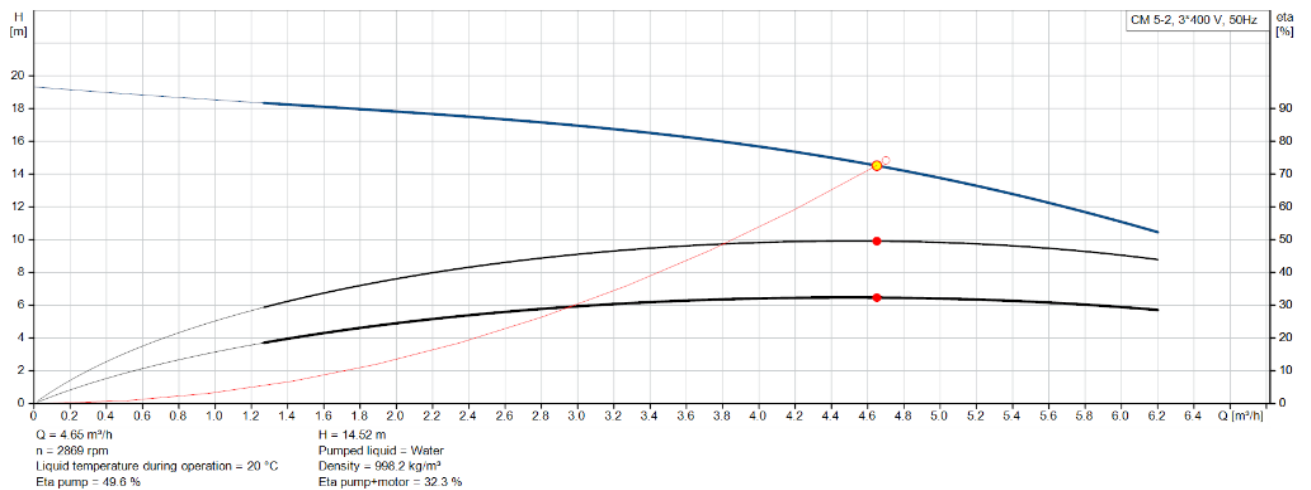

1RS5-5/8/GF - 2RS5-5/8/GF - 3RS5-5/8/GF PUMP CURVE

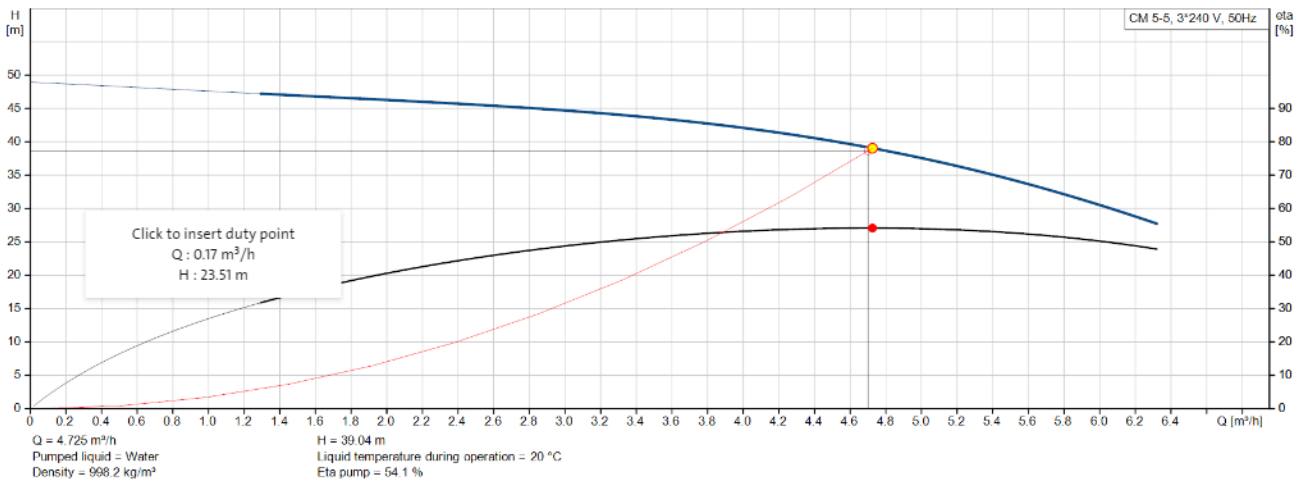

1RS5-7/8/GF - 2RS5-7/8/GF - 3RS5-7/8/GF PUMP CURVE

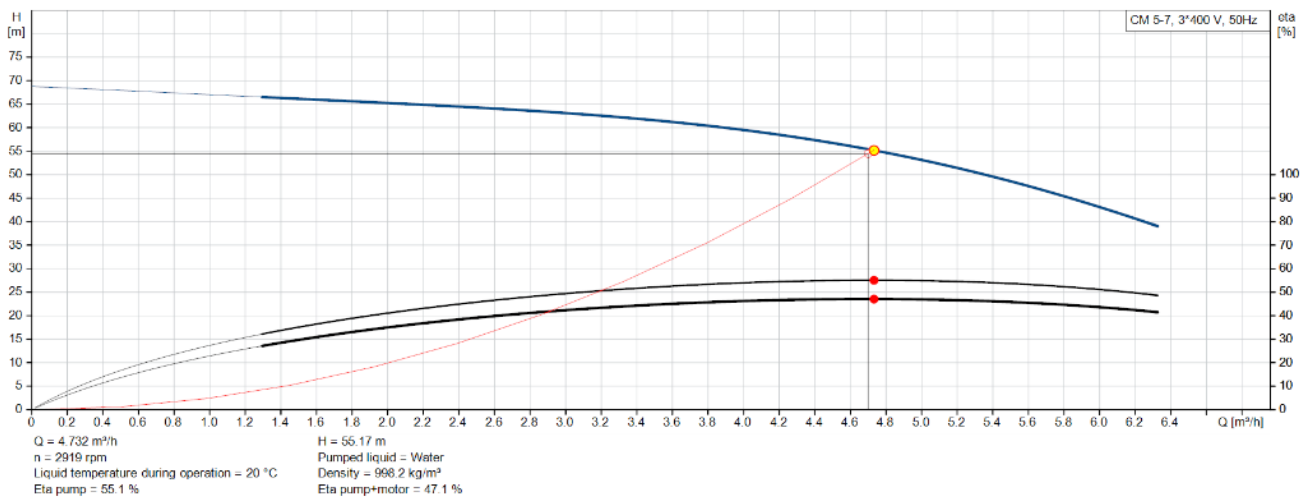

1RS5-8/8/GF - 2RS5-8/8/GF - 3RS5-8/8/GF PUMP CURVE

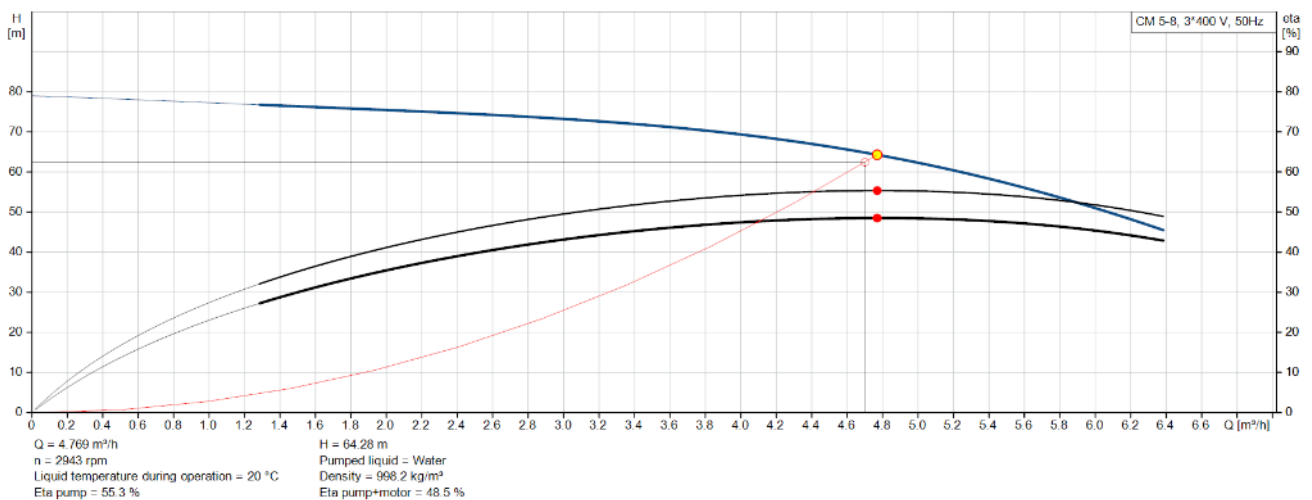

1RS5-9/8/GF - 2RS5-9/8/GF - 3RS5-9/8/GF PUMP CURVE

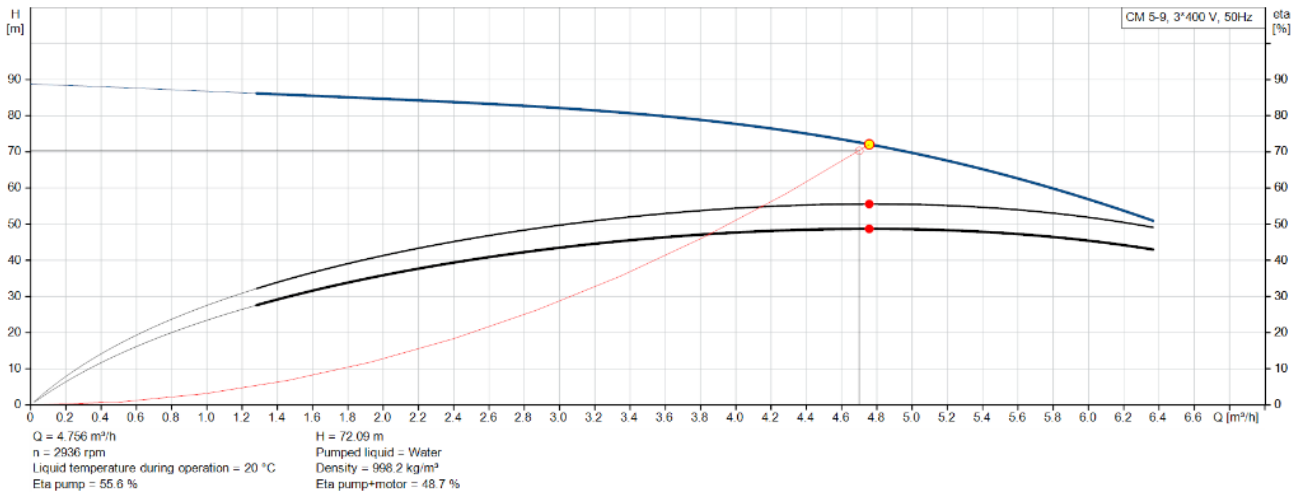

1RS10-2/8/GF - 2RS10-2/8/GF - 3RS10-2/8/GF PUMP CURVE

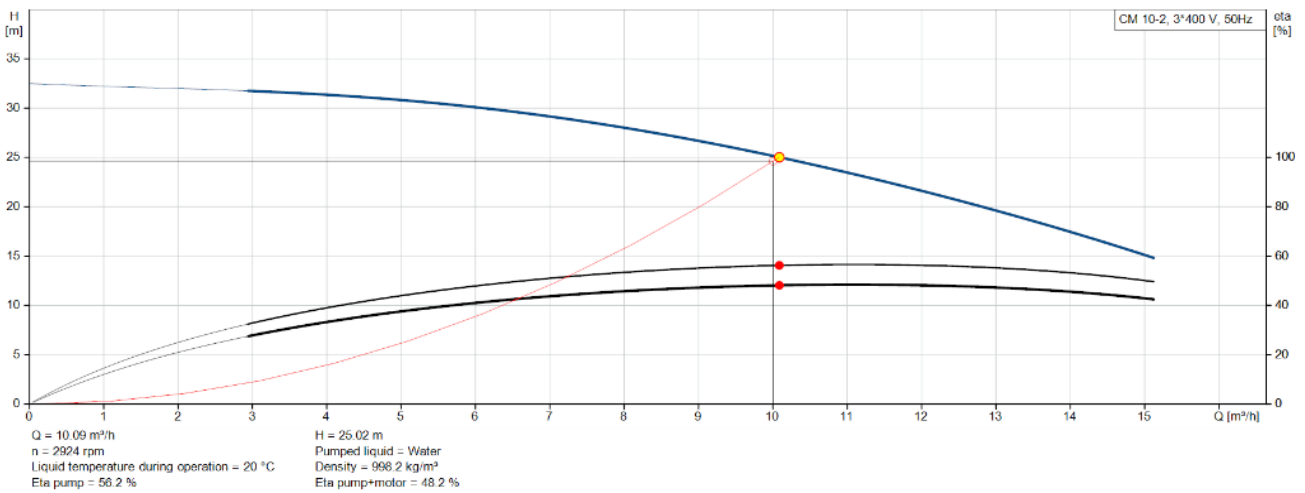

1RS10-3/8/GF - 2RS10-3/8/GF - 3RS10-3/8/GF PUMP CURVE

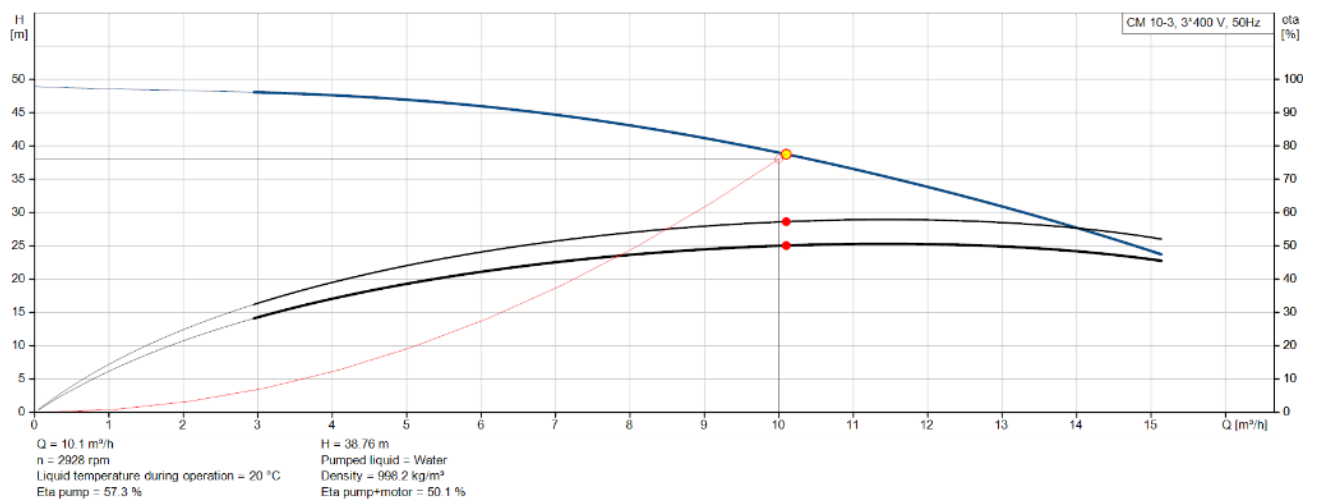



COMMISSIONING & SERVICING

Cold water booster sets require care and maintenance, that's why we offer unmatched support packages and commissioning to compliment your purchase.

- Commissioning
- Call outs
- Scheduled maintenance
- Chlorinations
- Service packages to suit requirements

WHY SERVICE YOUR BOOSTER SET?

An active service agreement vastly reduces the risk of equipment failing by ensuring that your cold water booster set is kept in working condition 24 hours a day.

Our team of highly experienced engineers can spot potential issues before they turn into a problem which could potentially damage your equipment which would lead to higher costs and disruption to your environment.

We'll always remind you when services are due and we'll make sure appointments are booked in well in advance to ensure our duty of care to the customer.

NATIONWIDE COVERAGE

We cover the vast majority of British Isles, this means we have engineers in place to get on-site quickly with the skills required to service your equipment.

All of our engineers are expertly trained and have a wide range of industry leading certifications, so you can be sure that any work is undertaken by a registered professional. Each engineer carries a wide range of tools and replacements to get your system up and running as fast as possible.

COMMISSIONING

It is highly advised to have your new cold water booster set commissioned by a DPT engineer to guarantee the installation has been done correctly. During the commissioning visit a DPT engineer will carry out the following tasks:-

- Set pump parameters
- Electrical connections of pump
- System cycle and test
- Evaluation of installation
- Commissioning certificate upon completion

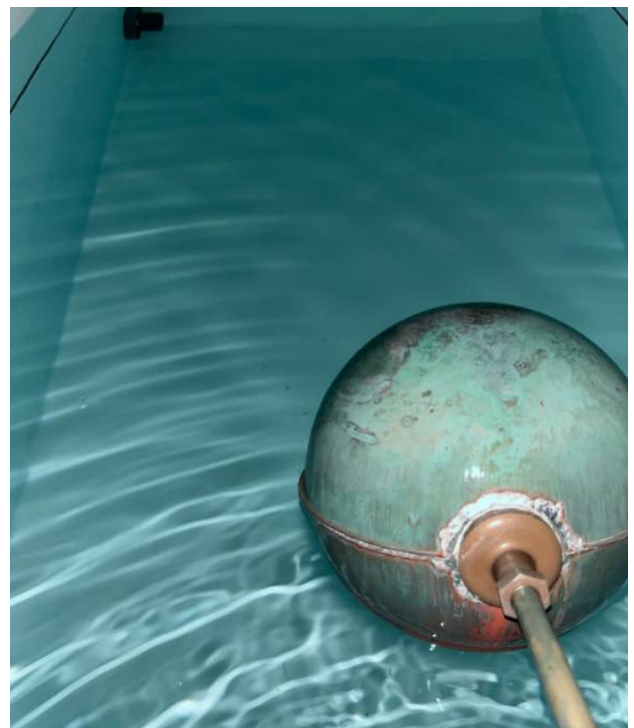

PLANNED MAINTENANCE

Regular maintenance of your cold water booster set is vital to ensure a long life, it is recommended that you have a yearly service of your equipment.

Each service will incorporate the following checks and adjustments:-

- A detailed inspection of mechanical components
- Full control system functionality check
- System adjustments where needed
- Visual inspection for leaks and operational issues
- Small remedial works where needed
- A full service report detailing all work

PRODUCT WARRANTY

DPT offers a full 1 year warranty on our products for a period of 12 months from the date of invoice.

Upon arrival, your cold booster set will come with a warranty card outlining all terms and conditions.

Extended warranties are available through service packages we can provide,

CHLORINATION

Water Utility companies will not allow connection of new water equipment onto their system until the system has been disinfected correctly.

We can provide services to issue certification of disinfection complying with local water authorities own specification to prevent the contamination of the water supply.

The external mains disinfection and chlorination is vital (and mandatory) to maintain the quality of the drinking water supply, this ensures that the water systems are safe to supply potable/wholesome water to outlets for drinking water and showers.

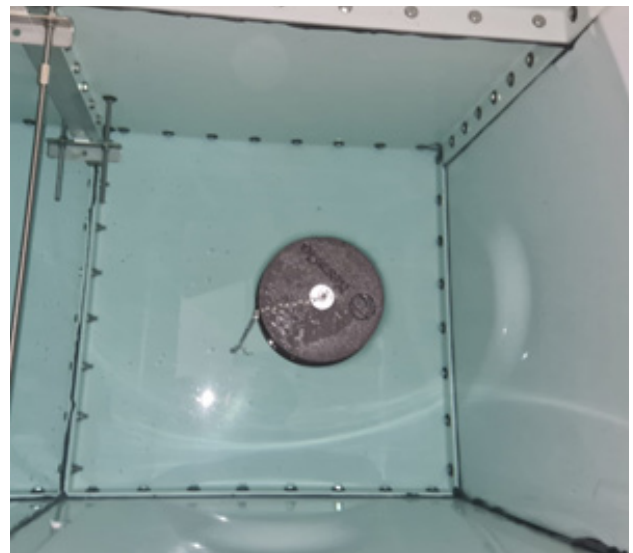

CONTACT DPT

If you would like to know more about this product, the services we offer, or have any questions, please contact us:-

SALES TEAM

0115 9444474 (Option 1)
enquiries@dpandt.co.uk

SERVICE TEAM

0115 9444474 (Option 3)
office@dpandtservices.co.uk

www.directpumpsandtanks.co.uk

DPT

DIRECTPUMPSANDTANKS.CO.UK