

View 1

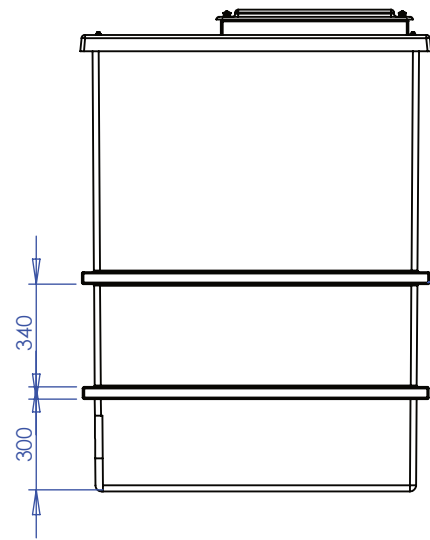

40mm STEEL BRACES

View 1

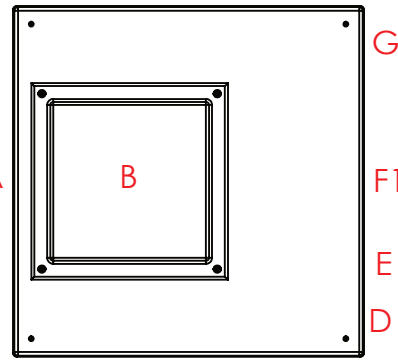

View 4

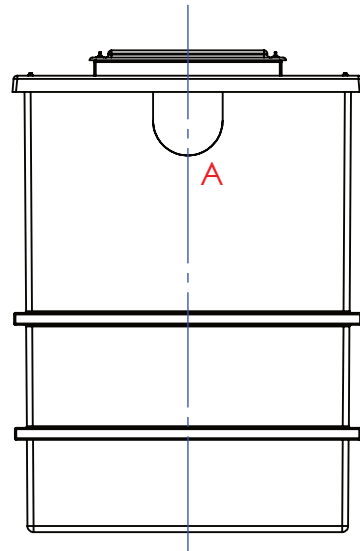

View 4

View 3

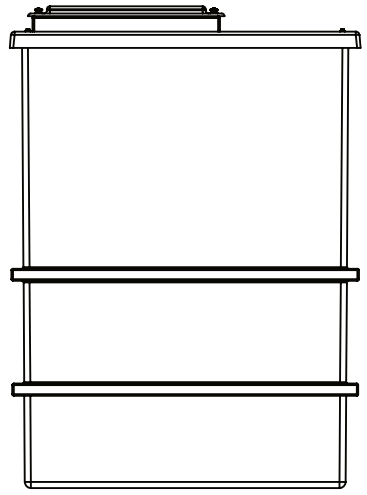

View 3

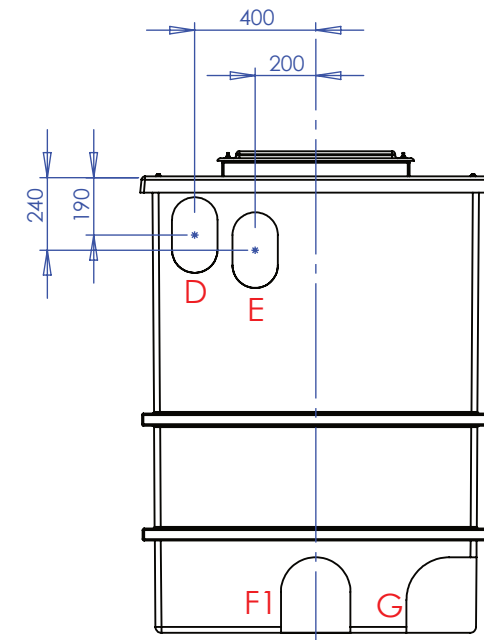

View 2

Connections:

- A - Inlet 1 No pad T1 only
- B - Lid vent None
- D - Overflow 1 No pad T2 only
- E - Warning pipe 1 No pad T2 only
- F1 - Outlet 1 No pad T1 only
- G - Drain 1 No pad T1 only

Drawing Approval Date	
Name	
Signature	
<p style="color: red; font-size: small;">I am signing to approve this drawing to progress my order in the build program. I accept that I cannot cancel this order following my signature of approval.</p>	

RUBBED DOWN BY	PRINT NAME
----------------	------------

TITLE	
STANDARD POSITIONS	
DRAWN BY	DATE
D.PRYJMACHUK	28/03/2024
CUSTOMER	CUSTOMER

NOTE:
All tanks must be fully supported on a flat, level & continuous foundation providing structural support to the tank when full to maximum operating capacity. It is essential that the user refers to the conditions of installation document prior to the installation of the tank. Under no circumstances should the tank body be used to provide support to pipework and ancillary items. The tank lid is a structural part of the tank and must be in place and fitted correctly when water is contained within the tank.

ALL DIMENSIONS +/- 5mm UNLESS OTHERWISE STATED

DESCRIPTION:

PW1501.INS.AG

ALL DIMENSIONS IN MM - DO NOT SCALE

NOTES		TANK SPECIFICATION :	
DATE	21/03/2024	INTERNAL DIMENSIONS	1000 x 1000 x 1500mm
FIRST ISSUE	xxx	EXTERNAL DIMENSIONS	1160 x 1160 x 1600mm
VERSION	xxx	NOMINAL CAPACITY	1500 Litres
		INSULATION THICKNESS	25mm
		STEEL BRACINGS	40mm STEEL BRACES
		ENCAPSULATED BASEBOARD	NONE
		TANK COLOUR	GREY - 00A05



SCALE:1:25

SHEET 1 OF 1