

2575 - External Width

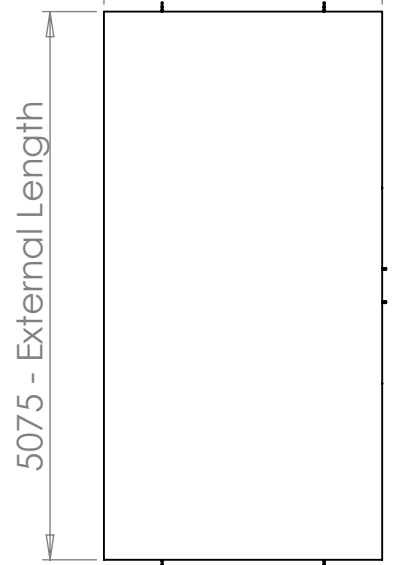

5075 - External Length

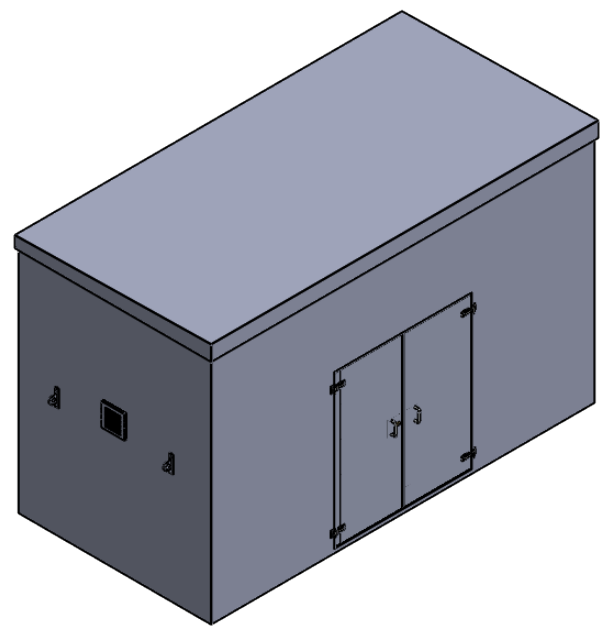

Sloped Roof

3200 - External Height

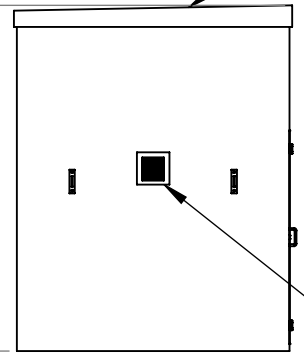

Louvered vent

1800 - Door Opening

2000 - Door Opening

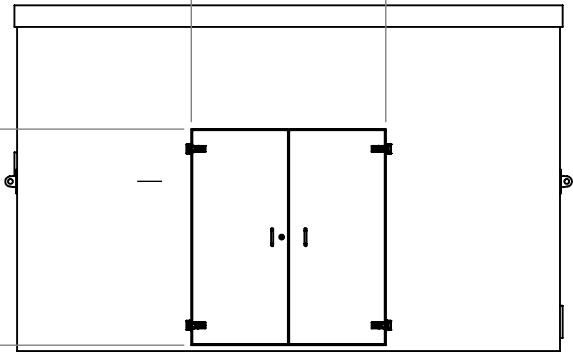

TITLE	
PWHG.5x2.5x3	
DRAWN BY	DATE
C.Larkin	23/05/2024

Foundation Requirements:
 The foundation area must be no less in length and width than the external dimensions of the enclosure. The foundation must be constructed so as to be capable of supporting the weight of the enclosure and equipment contained within it. The foundation must be continuous and be no more than ±2mm over any given metre.

DESCRIPTION:	
PWHG.5x2.5x3	
KIOSK	
SCALE:1:70	SHEET 1 OF 2

TANK SPECIFICATION :	
INTERNAL DIMENSIONS	4860 x 2360 x 3000mm
EXTERNAL DIMENSIONS	5075 x 2575 x 3200mm
INSULATION THICKNESS	18mm
MATERIAL	GRP - GREY



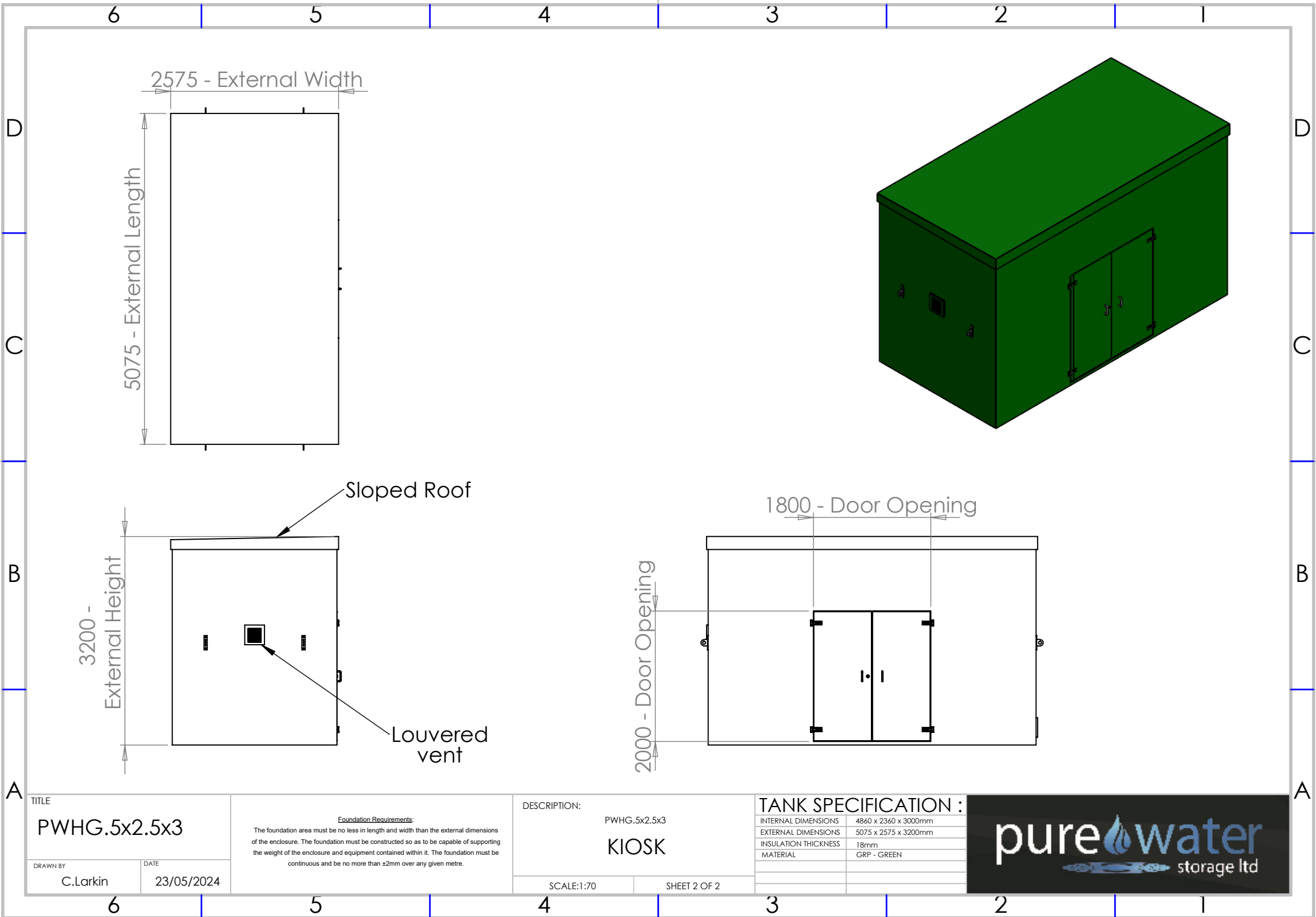

TITLE
PWHG.5x2.5x3

DRAWN BY
 C.Larkin

DATE
 23/05/2024

Foundation Requirements:
 The foundation area must be no less in length and width than the external dimensions of the enclosure. The foundation must be constructed so as to be capable of supporting the weight of the enclosure and equipment contained within it. The foundation must be continuous and be no more than ±2mm over any given metre.

DESCRIPTION:
 PWHG.5x2.5x3
KIOSK

SCALE:1:70

SHEET 2 OF 2

TANK SPECIFICATION :

INTERNAL DIMENSIONS	4860 x 2360 x 3000mm
EXTERNAL DIMENSIONS	5075 x 2575 x 3200mm
INSULATION THICKNESS	18mm
MATERIAL	GRP - GREEN

