

3075 - External Width

8075 - External Length

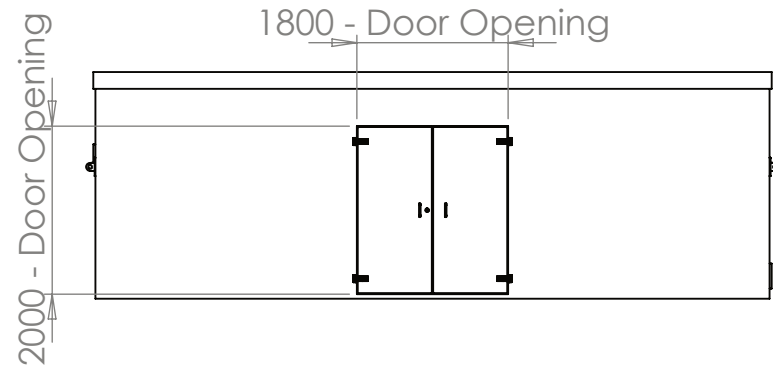
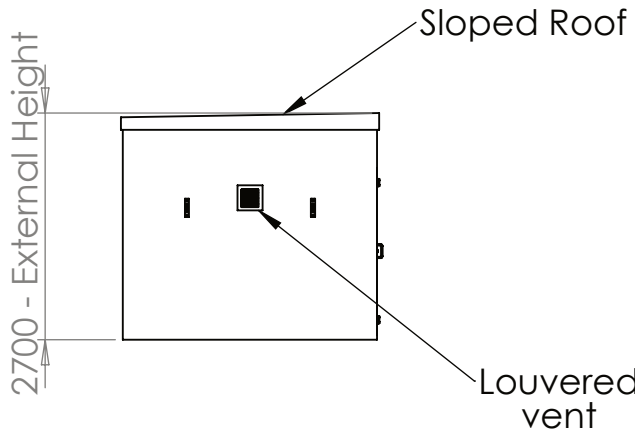
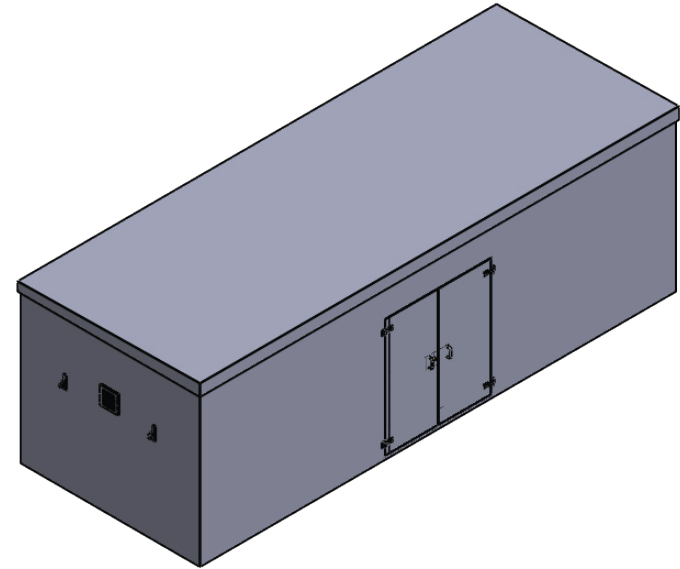
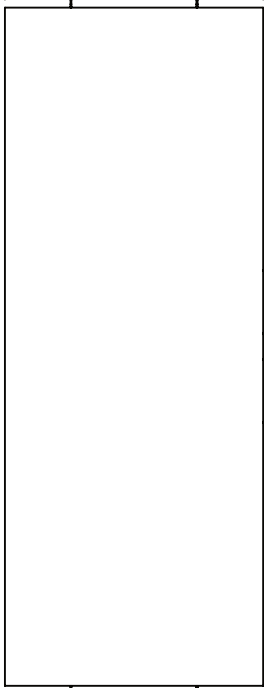

TITLE  
PWHG.8x3x2.5-50

DRAWN BY: C.Larkin  
DATE: 23/05/2024

**Foundation Requirements:**  
The foundation area must be no less in length and width than the external dimensions of the enclosure. The foundation must be constructed so as to be capable of supporting the weight of the enclosure and equipment contained within it. The foundation must be continuous and be no more than ±2mm over any given metre.

DESCRIPTION:  
PWHG.8x3x2.5-50  
KIOSK

SCALE:1:90 SHEET 1 OF 2

TANK SPECIFICATION :

INTERNAL DIMENSIONS	7700 x 2700 x 2500mm
EXTERNAL DIMENSIONS	8075 x 3075 x 2700mm
INSULATION THICKNESS	50mm
MATERIAL	GRP - GREY



3075 - External Width

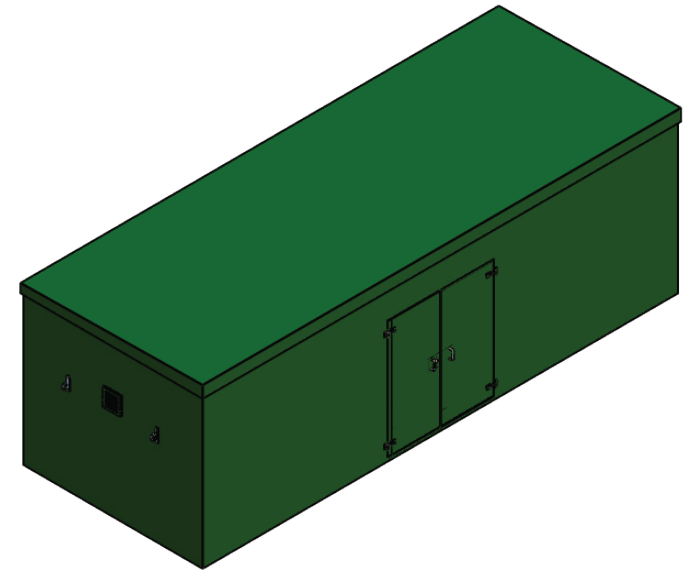

Sloped Roof

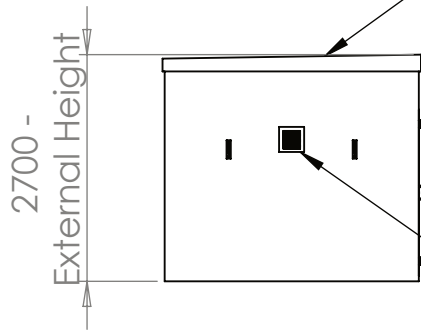

1800 - Door Opening

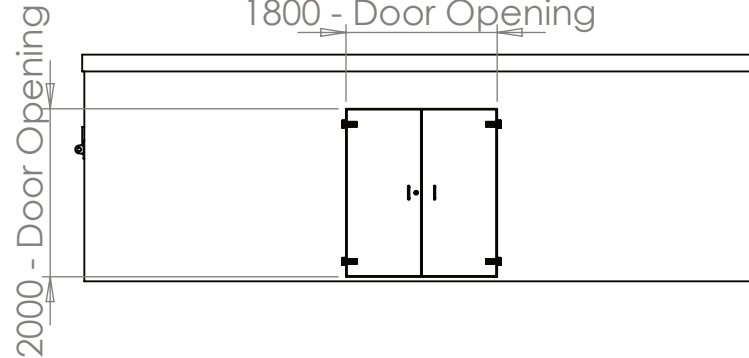

TITLE  
**PWHG.8x3x2.5-50**

DRAWN BY: C.Larkin  
 DATE: 23/05/2024

**Foundation Requirements:**  
 The foundation area must be no less in length and width than the external dimensions of the enclosure. The foundation must be constructed so as to be capable of supporting the weight of the enclosure and equipment contained within it. The foundation must be continuous and be no more than ±2mm over any given metre.

DESCRIPTION:  
 PWHG.8x3x2.5-50  
**KIOSK**

SCALE:1:90 SHEET 2 OF 2

**TANK SPECIFICATION :**

INTERNAL DIMENSIONS	7700 x 2700 x 2500mm
EXTERNAL DIMENSIONS	8075 x 3075 x 2700mm
INSULATION THICKNESS	50mm
MATERIAL	GRP - GREEN

