

2075 - External Width

8075 - External Length

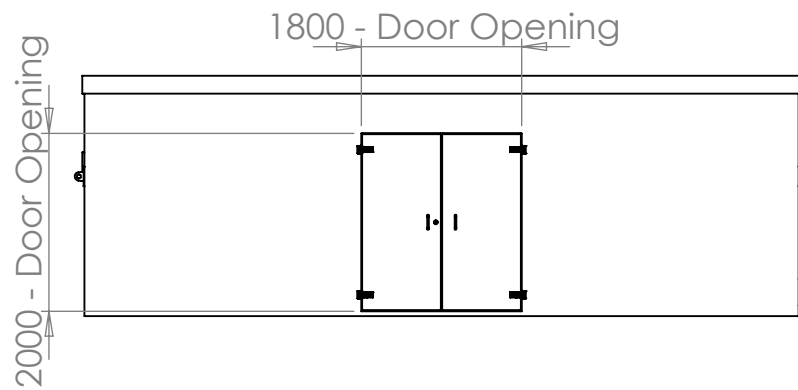
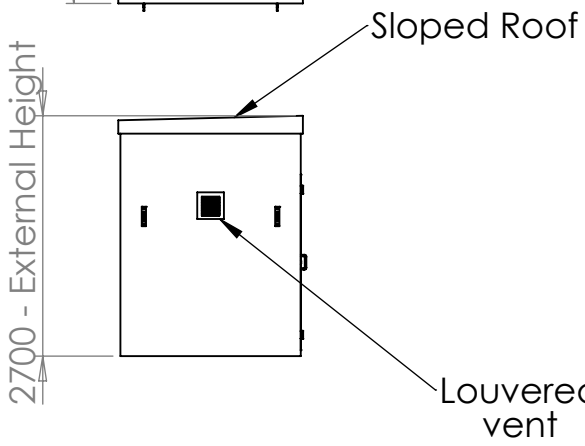
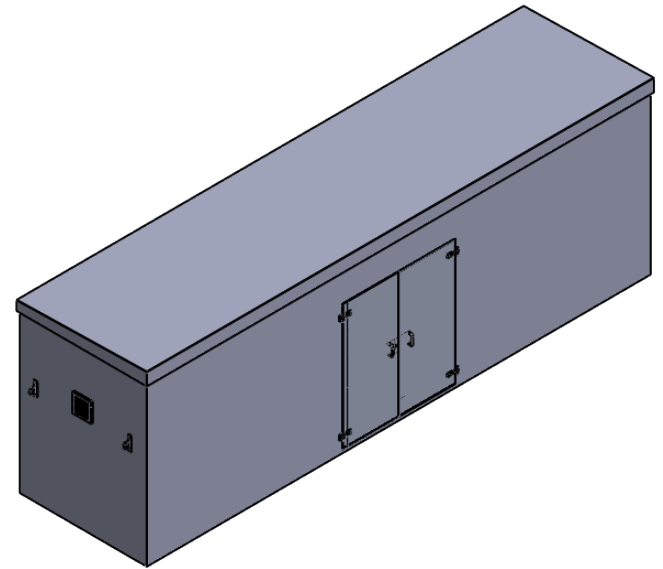
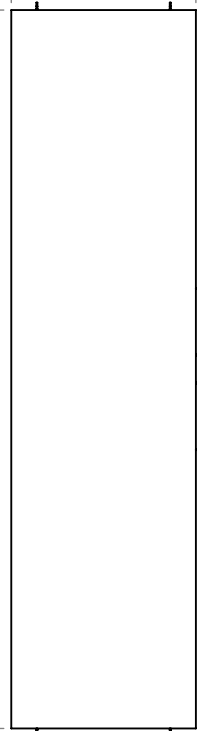

TITLE	
PWHG.8x2x2.5	
DRAWN BY	DATE
C.Larkin	23/05/2024

Foundation Requirements:
 The foundation area must be no less in length and width than the external dimensions of the enclosure. The foundation must be constructed so as to be capable of supporting the weight of the enclosure and equipment contained within it. The foundation must be continuous and be no more than ±2mm over any given metre.

DESCRIPTION:	
PWHG.8x2x2.5	
KIOSK	
SCALE:1:85	SHEET 1 OF 2

TANK SPECIFICATION :	
INTERNAL DIMENSIONS	7860 x 1860 x 2500mm
EXTERNAL DIMENSIONS	8075 x 2075 x 2700mm
INSULATION THICKNESS	18mm
MATERIAL	GRP - GREY



2075 - External Width

8075 - External Length

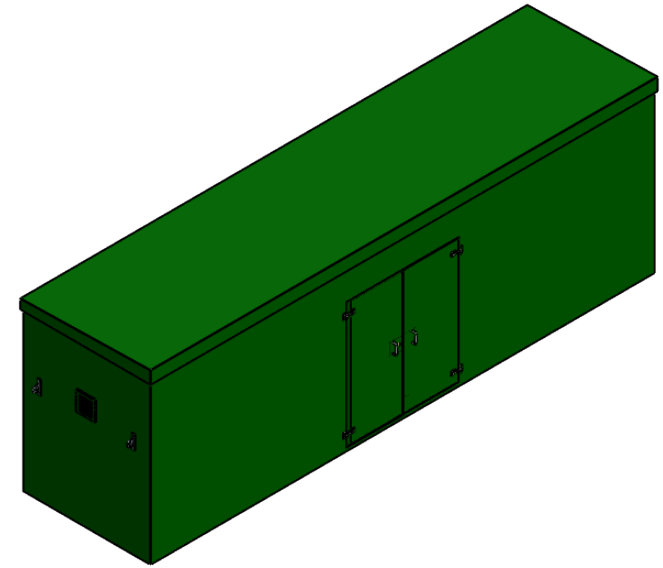
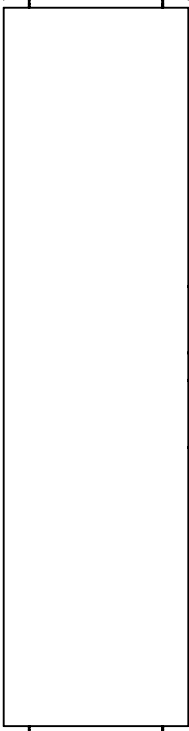

Sloped Roof

2700 - External Height

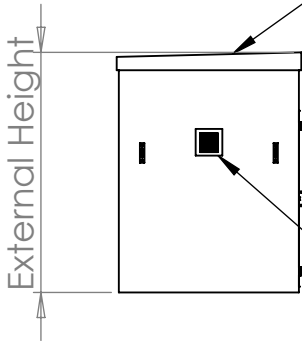

Louvered vent

1800 - Door Opening

2000 - Door Opening

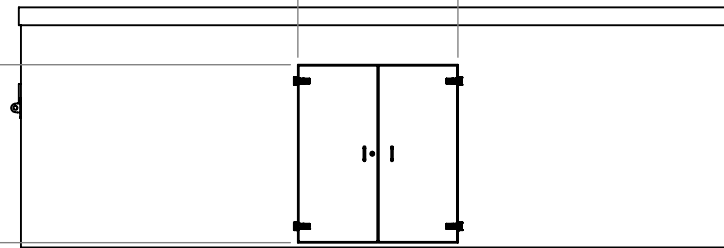

TITLE
PWHG.8x2x2.5

DRAWN BY
C.Larkin

DATE
23/05/2024

Foundation Requirements:
The foundation area must be no less in length and width than the external dimensions of the enclosure. The foundation must be constructed so as to be capable of supporting the weight of the enclosure and equipment contained within it. The foundation must be continuous and be no more than ±2mm over any given metre.

DESCRIPTION:
PWHG.8x2x2.5
KIOSK

SCALE:1:85 SHEET 2 OF 2

TANK SPECIFICATION :

INTERNAL DIMENSIONS	7860 x 1860 x 2500mm
EXTERNAL DIMENSIONS	8075 x 2075 x 2700mm
INSULATION THICKNESS	18mm
MATERIAL	GRP - GREEN

