

2075 - External Width

7075 - External Length

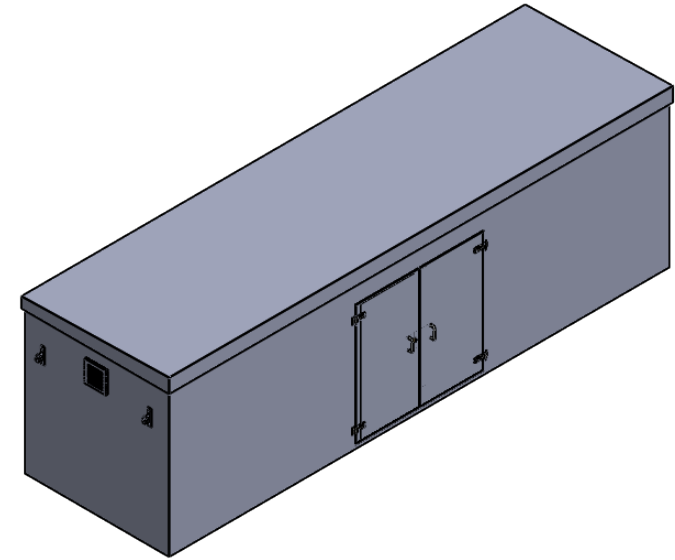
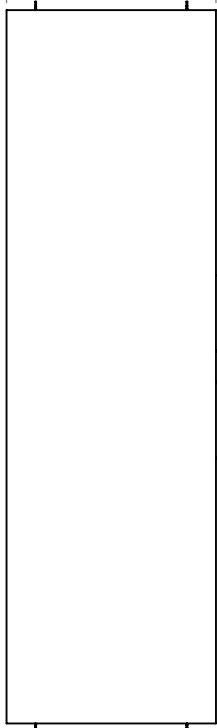

2200 - External Height

Sloped Roof

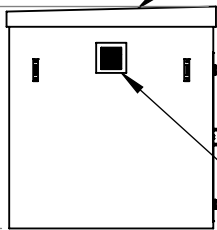

Louvered vent

1700 - Door Opening

1800 - Door Opening

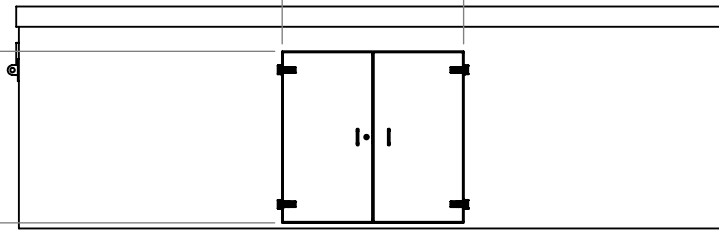

TITLE
PWHG.7x2x2-50

DRAWN BY
C.Larkin

DATE
23/05/2024

Foundation Requirements:
The foundation area must be no less in length and width than the external dimensions of the enclosure. The foundation must be constructed so as to be capable of supporting the weight of the enclosure and equipment contained within it. The foundation must be continuous and be no more than ±2mm over any given metre.

DESCRIPTION:
PWHG.7x2x2-50
KIOSK

SCALE:1:75 SHEET 1 OF 2

TANK SPECIFICATION :

INTERNAL DIMENSIONS	6700 x 1700 x 2000mm
EXTERNAL DIMENSIONS	7075 x 2075 x 2200mm
INSULATION THICKNESS	50mm
MATERIAL	GRP - GREY



2075 - External Width

7075 - External Length

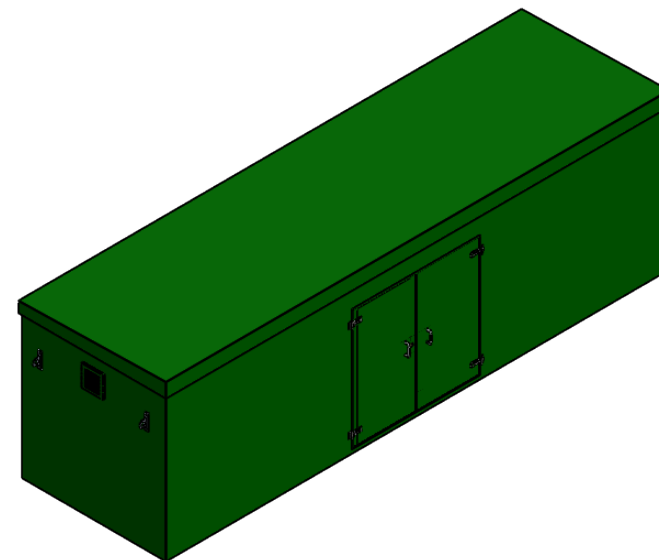
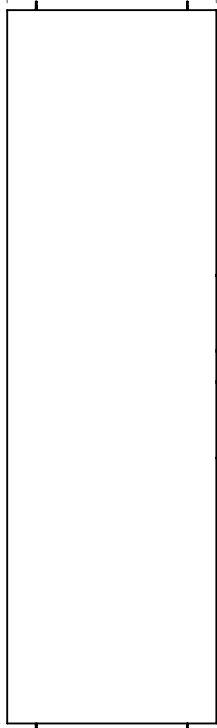

Sloped Roof

2200 - External Height

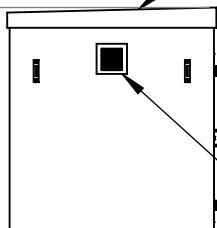

Louvered vent

1800 - Door Opening

1700 - Door Opening

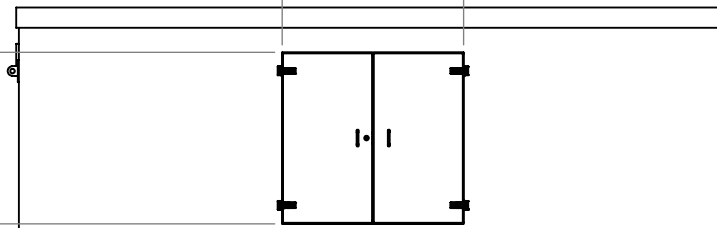

TITLE
PWHG.7x2x2-50

DRAWN BY
C.Larkin

DATE
23/05/2024

Foundation Requirements:
The foundation area must be no less in length and width than the external dimensions of the enclosure. The foundation must be constructed so as to be capable of supporting the weight of the enclosure and equipment contained within it. The foundation must be continuous and be no more than ±2mm over any given metre.

DESCRIPTION:
PWHG.7x2x2-50
KIOSK

SCALE:1:75 SHEET 2 OF 2

TANK SPECIFICATION :

INTERNAL DIMENSIONS	6700 x 1700 x 2000mm
EXTERNAL DIMENSIONS	7075 x 2075 x 2200mm
INSULATION THICKNESS	50mm
MATERIAL	GRP - GREEN

