

TITLE
PWHG.6x2x2-50

DRAWN BY
 C.Larkin

DATE
 23/05/2024

Foundation Requirements:
 The foundation area must be no less in length and width than the external dimensions of the enclosure. The foundation must be constructed so as to be capable of supporting the weight of the enclosure and equipment contained within it. The foundation must be continuous and be no more than ±2mm over any given metre.

DESCRIPTION:
 PWHG.6x2x2-50
KIOSK

SCALE:1:65

SHEET 1 OF 2

TANK SPECIFICATION :

INTERNAL DIMENSIONS	5700 x 1700 x 2000mm
EXTERNAL DIMENSIONS	6075 x 2075 x 2200mm
INSULATION THICKNESS	50mm
MATERIAL	GRP - GREY



2075 - External Width

6075 - External Length

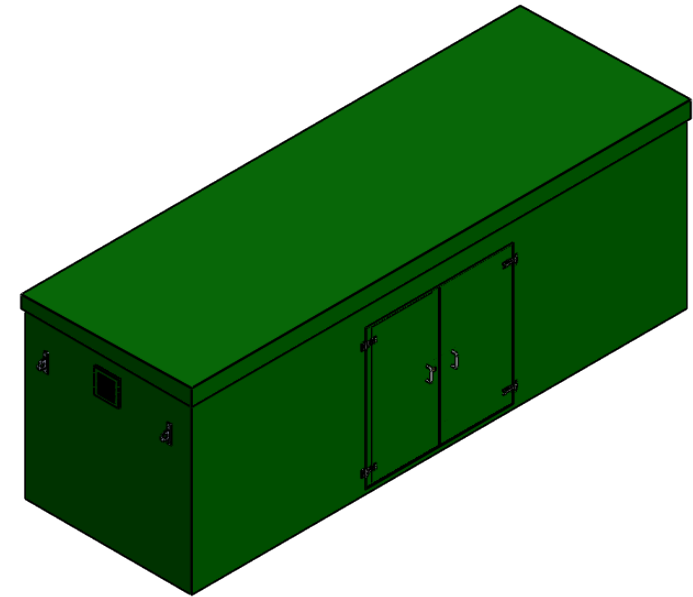
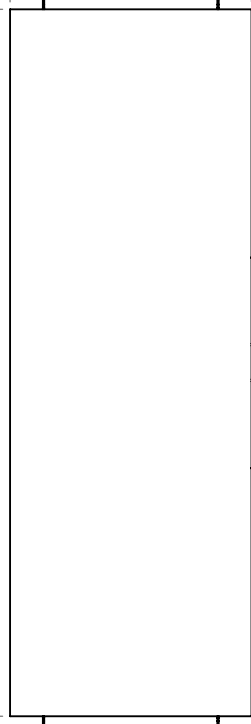

Sloped Roof

2200 - External Height

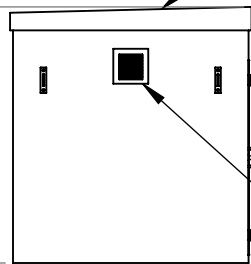

Louvered vent

1800 - Door Opening

1700 - Door Opening

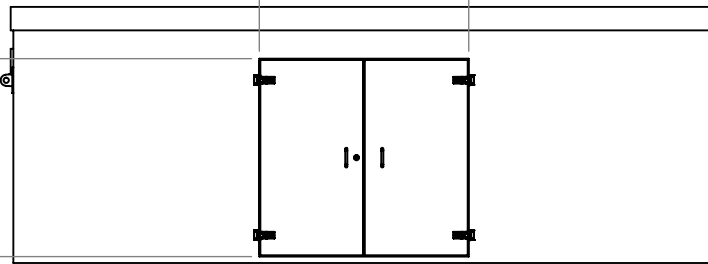

TITLE

PWHG.6x2x2-50

DRAWN BY: C.Larkin DATE: 23/05/2024

Foundation Requirements:
 The foundation area must be no less in length and width than the external dimensions of the enclosure. The foundation must be constructed so as to be capable of supporting the weight of the enclosure and equipment contained within it. The foundation must be continuous and be no more than ±2mm over any given metre.

DESCRIPTION: PWHG.6x2x2-50

KIOSK

SCALE:1:65 SHEET 2 OF 2

TANK SPECIFICATION :

INTERNAL DIMENSIONS	5700 x 1700 x 2000mm
EXTERNAL DIMENSIONS	6075 x 2075 x 2200mm
INSULATION THICKNESS	50mm
MATERIAL	GRP - GREEN

