

© Oaklands Environmental Ltd 2024. We reserve the right to change specification without prior notice in line with our policy of continuous development.

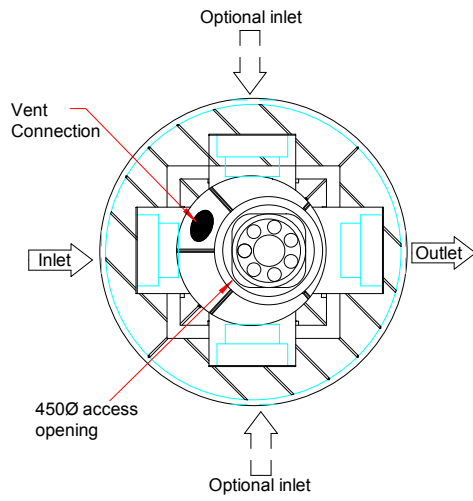

| | |
|------------------|-----------------------|
| Area Drained | 10,000 m ² |
| Nominal size | 18 |
| Flow rate | 18 l/sec |
| Peak flow | 180 l/sec |
| Connections | 110 - 160 Ø |
| Oil storage | 270 litres |
| Working capacity | 3400 litres |
| Diameter | 1560 mm |
| Approx. height | 2800 mm |

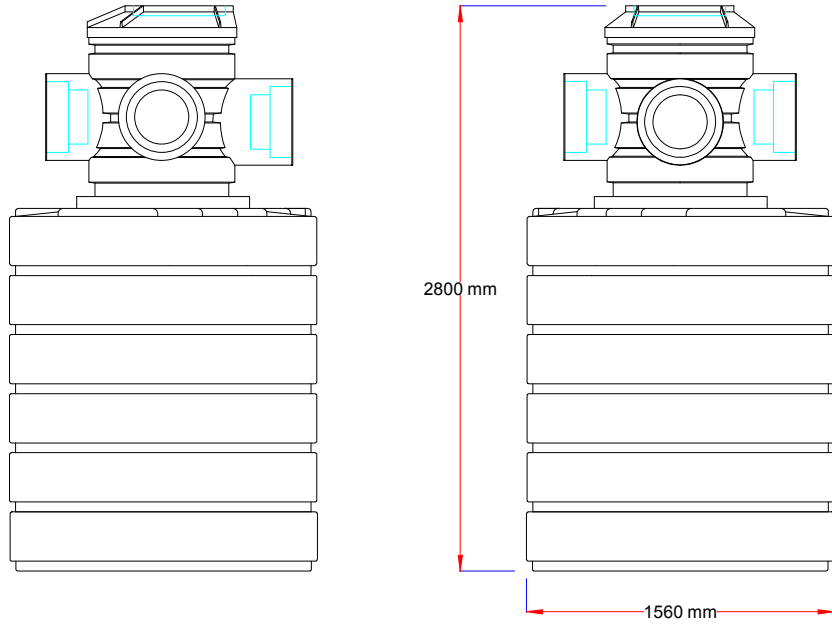

sales@oaklandsenvironmental.com
www.oaklandsenvironmental.com

| REV | DETAIL |
|-----|-------------------------|
| 1 | Re-issued as NSB18 only |
| 2 | New Geceptor top added |

| | |
|----------|-----------------------------------|
| TITLE | NSB18 General arrangement drawing |
| CUSTOMER | |

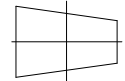
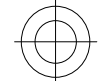
| | |
|------------------------|---|
| DRAWING NO | GA1063/24 |
| THIRD ANGLE PROJECTION |   |
| TOLERANCE +/- 2% | |
| SCALE | NOT TO SCALE |
| SHEET | 1 of 1 |
| REV | 2 |