

Area Drained	8333 m ²
Nominal size	15
Flow rate	15 l/sec
Peak flow	150 l/sec
Connections	110 - 160Ø
Oil storage	225 litres
Working capacity	1800 litres
Diameter	1260 mm
Approx. height	2550 mm

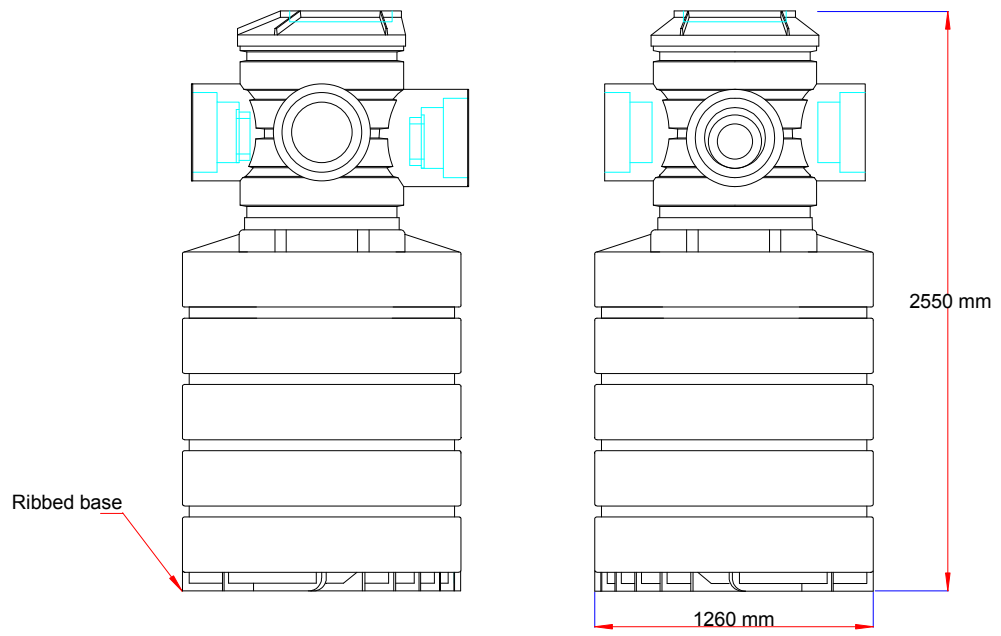

Oaklands
Environmental Ltd

sales@oaklandsenvironmental.com
www.oaklandsenvironmental.com

REV	DETAIL
1	Amended 1215 base
2	New Geceptor top and ribbed base
3	Radius added to outer ribs

TITLE	NSB15 General arrangement
CUSTOMER	

DRAWING NO	GA1066/24
THIRD ANGLE PROJECTION	SCALE
	NOT TO SCALE
	SHEET
	1 of 1
TOLERANCE +/- 2%	REV 3