

Area Drained	6,940 m <sup>2</sup>
Nominal size	12.5
Flow rate	12.5 l/sec
Peak flow	125 l/sec
Connections	110 - 160 Ø
Oil storage	187.50 litres
Working capacity	1800 litres
Diameter	1260 mm
Approx. height	2550 mm

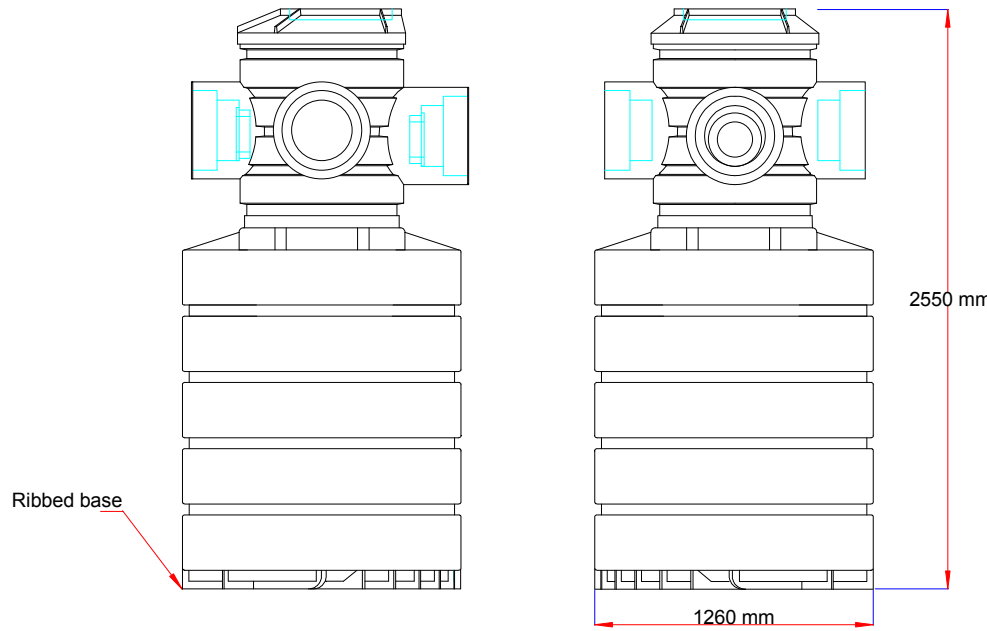

REV	DETAIL		
2	Amended 1215 base		
3	New Geceptor top and ribbed base		
4	Radius added to outer ribs		

TITLE	NSB12.5 General arrangement
CUSTOMER	

DRAWING NO	GA1062/24		
THIRD ANGLE PROJECTION		SCALE	NOT TO SCALE
		SHEET	1 of 1
TOLERANCE +/- 2%		REV	4